

# ▶ Bicycle pocket guide



USA

ROYAL DUTCH  
**Gazelle**



## That's my ride

Gazelle has been making bikes since 1892. This has given us the knowledge and innovation to make the very best bikes. We work with passion and dedicate ourselves to surprising design and smart innovations. We think of every detail and do not compromise on quality, safety, or comfort. We do everything we can to ensure that our bikes are an attractive alternative for your daily ride.

Today, tomorrow, or in the future, Gazelle is ready to help every cyclist and offer a great cycling experience. Find the Gazelle e-bike that matches your personal needs in this pocket guide, or go to **[gazellebikes.com/en-us](https://gazellebikes.com/en-us)**.

# Ultimate



## Ultimate feeling of freedom

The Ultimate lets you make the most of your leisure time, your weekend adventures, or your commute. And it rides just like it looks: super comfortably with a sporty look. Characterized by its innovative and dynamic design, the Ultimate is a feast for the eyes. And its unique motor, battery, and cable integration give the Ultimate a sleek and stylish presence. Sports cycling has never been so comfortable. Discover it for yourself.

[www.gazellebikes.com/en-us/models/gazelle-ultimate](http://www.gazellebikes.com/en-us/models/gazelle-ultimate)

## Frame Geometry

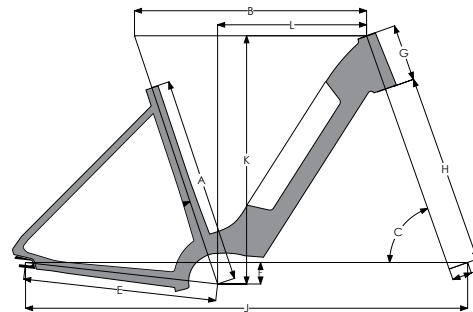

Frame size	Ultimate T10+ HMB & C380+ HMB			Ultimate T10 HMB & C380 HMB   Ultimate C8 HMB*					
	S (46)	M (53)	L (57)	S (46)		M (53)		L (57)	
<b>A</b> Size (mm)	460	530	570	460		530		570	
<b>B</b> Effective top tube length (mm)	593	593	613	603	593*	603	593*	623	613*
<b>C</b> Head tube angle (°)	70,5	70,5	70,5	70,5		70,5		70,5	
<b>D</b> Effective seat tube angle (°)	71,5	71,5	71,5	71,5		71,5		71,5	
<b>E</b> Chain stay length (mm)	472	472	472	494		494		494	
<b>F</b> BB Drop (mm)	55	55	55	55		55		55	
<b>G</b> Head tube length (mm)	145	145	165	150	145*	150	145*	170	165*
<b>H</b> Fork length (mm)	485	485	485	485		485		485	
<b>I</b> Fork offset (mm)	50	50	50	50		50		50	
<b>J</b> Wheelbase (mm)	1108	1108	1128	1141	1131*	1141	1131*	1161	1151*
<b>K</b> Stack (mm)	635	635	653	639	635*	639	635*	659	653*
<b>L</b> Reach (mm)	381	381	394	381	381*	389	381*	403	394*

## GAZELLE ULTIMATE C380+ HMB



- Powerful assistance thanks to a Bosch Performance Line Speed motor with 85 Nm of torque (28mph) and 500 Wh integrated battery
- Premium Shimano disc brakes for smooth and responsive braking
- Enviolo 380 trekking hub provides effortless and stepless shifting
- Comfort, design, and performance combined in a single sporty bike



**DESCRIPTION** Enviolo 380 Trekking with Shimano BR-MT420 hydraulic disc brakes **WEIGHT (KG)** 25,2 (excl. battery) **LBS** 55.6 (excl. battery) **COLOR** industry grey matte  
**HIGH-STEP** M(53) | L(57) **COLOR** industry grey matte  
**MID-STEP** S(46) | M(53) | L(57)

*Dual battery kit available for all high-step frames*

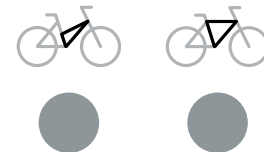

## GAZELLE ULTIMATE T10+ HMB



- Bosch Performance Line Speed motor (85 Nm) providing support up to 28 mph with integrated 500 Wh battery
- Great quality derailleur and powerful disc brakes for a sporty and confident performance
- Suspension front fork, wide tires, and a relaxed posture provide extra comfort
- Dual battery capability doubles range potential



**DESCRIPTION** 10-speed Shimano Deore gears with Shimano BR-MT420 hydraulic disc brakes **WEIGHT (KG)** 23,2 (excl. battery) **LBS** 51.1 (excl. battery) **COLOR** champion red or orion blue matte **HIGH-STEP** M(53) | L(57) **COLOR** cloud grey **MID-STEP** S(46) | M(53) | L(57)

*Dual battery kit available for all high-step frames*

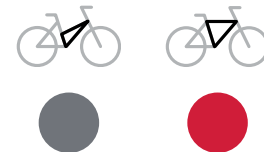

## GAZELLE ULTIMATE C380 HMB



- Sportive support and long lasting range with the Bosch Performance Line motor (75 Nm) providing pedal-assistance up to 20 mph with integrated 625 Wh battery
- High-grade Shimano disc brakes for optimal braking performance
- Use of Enviolo trekking hub means effortless and stepless shifting
- Comfort, design and performance combined in a single sporty bike

**DESCRIPTION** Enviolo Trekking Manual stepless gear system with Shimano hydraulic disc brakes **WEIGHT (KG)** 25,6 (excl. battery) **LBS** 56.4 (excl. battery) **COLOR** denim blue or mallard blue **LOW-STEP** S(46) | M(53) | L(57)



## GAZELLE ULTIMATE T10 HMB



- Sportive support and long lasting range with the Bosch Performance Line motor (75 Nm) providing pedal-assistance up to 20 mph with integrated 625 Wh battery
- High-grade Shimano disc brakes for optimal braking performance
- Integrated lighting to see and be seen
- Relaxed posture combined with powerful performance mean that no trip is too far

**DESCRIPTION** 10-speed Shimano Deore gears with Shimano hydraulic disc brakes **WEIGHT (KG)** 24,3 (excl. battery) **LBS** 53.6 (excl. battery) **COLOR** frozen white or thunder grey **LOW-STEP** S(46) | M(53) | L(57) **COLOR** thunder grey **HIGH-STEP** M(53) | L(57)

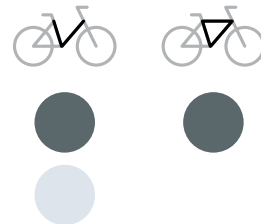

## GAZELLE ULTIMATE C8 HMB



- Reliable assistance thanks to a Bosch Active Line Plus motor with 50 Nm of torque (20 mph) and 500 Wh integrated battery
- A super stable and rigid frame provides an optimal handling experience
- High-grade Shimano disc brakes for optimal braking performance
- Durable, low maintenance Nexus 8 hub and Gates belt drive



**DESCRIPTION** 8-speed Shimano Nexus gears with Shimano BR-MT200 hydraulic disc brakes **WEIGHT (KG)** 24,4 (excl. battery) **LBS** 53.8 (excl. battery) **COLOR** light sienna matte or petrol blue matte **LOW-STEP** S(46) | M(53) | L(57)  
*Dual battery kit available for Low Step frames 53cm and 57cm*





# Medeo



## Sporty and comfortable

Gazelle Medeo combines the best of both worlds. The performance and style components are based on sports bicycles and the comfort and ease of use are derived from urban bicycles. Extra performance is obtained from the powerful Bosch Performance motor, which excels in challenging hilly areas while assisting you silently. The result is a comfortable and sporty e-bike you can use to navigate smoothly through town and which is suitable for the longer road to work. [www.gazellebikes.com/en-us/models/gazelle-medeo](http://www.gazellebikes.com/en-us/models/gazelle-medeo)

## Frame Geometry

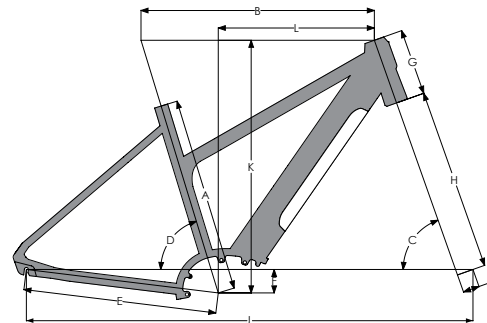

Frame size	Medeo T10+ HMB			Medeo T10 HMB, T9 HMB & T9 City HMB		
	S (45)	M (50)	L (55)	S (45)	M (50)	L (55)
<b>A</b> Size (mm)	450	500	550	450	500	550
<b>B</b> Effective top tube length (mm)	580	597	614	580	597	614
<b>C</b> Head tube angle (°)	70,5	70,5	70,5	70,5	70,5	70,5
<b>D</b> Effective seat tube angle (°)	73	73	73	73	73	73
<b>E</b> Chain stay length (mm)	460	460	460	494	494	494
<b>F</b> BB Drop (mm)	60	60	60	60	60	60
<b>G</b> Head tube length (mm)	160	170	170	160	170	170
<b>H</b> Fork length (mm)	464	464	464	450	450	450
<b>I</b> Fork offset (mm)	42	42	42	60	60	60
<b>J</b> Wheelbase (mm)	1090	1108	1125	1125	1142	1159
<b>K</b> Stack (mm)	637	646	646	637	646	646
<b>L</b> Reach (mm)	385	399	417	385	399	417

## GAZELLE MEDEO T10+ HMB



- Powerful assistance thanks to a Bosch Performance Line Speed motor with 85 Nm of torque (28 mph) and 500 Wh integrated battery
- Great quality derailleur and powerful disc brakes for a comfortable commute and /or recreational trips
- A 63mm suspension front fork combined with wide tires provide extra comfort
- Dual battery capability to extend your ride beyond previous possibilities



**DESCRIPTION** 10 speed Shimano Deore with Shimano BR-MT420 hydraulic disc brakes **WEIGHT (KG)** 23,1 (excl. battery) **LBS** 50.9 (excl. battery) **COLOR** mallard blue **HIGH-STEP** S(45) | M(50) | L(55) **COLOR** petrol blue **MID-STEP** S(45) | M(50) | L(55)

*Dual battery kit available for all frame sizes*

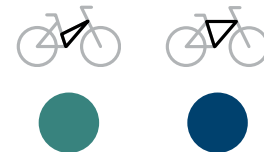

## GAZELLE MEDEO T10 HMB



- Powerful assistance thanks to a Bosch Performance Line motor with 65 Nm of torque (20mph) and 500Wh integrated battery
- Dynamic frame with great riding characteristics
- Great quality derailleur and powerful disc brakes for a comfortable commute and/or recreational trips
- A 50mm suspension front fork combined with wide tires provide extra comfort



**DESCRIPTION** 10-speed Shimano Deore gears with Shimano BR-MT200 hydraulic disc brakes **WEIGHT (KG)** 22,5 (excl. battery) **LBS** 49.6 (excl. battery) **COLOR** anthracite grey **HIGH-STEP** S(45) | M(50) | L(55) **COLOR** denim blue or ivory white **MID-STEP** S(45) | M(50) | L(55)

*Dual battery kit available for all frame sizes*

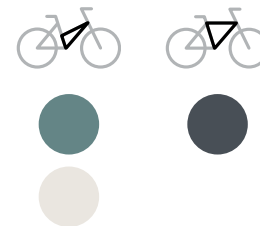

## GAZELLE MEDEO T9 HMB



- Smooth assistance thanks to a Bosch Active Line Plus motor with 50 Nm of torque (20mph) and 400Wh rack battery
- Dynamic low-step frame with carrier battery, high-step frame with battery on the down tube
- Smooth derailleur and powerful disc brakes for a comfortable commute and /or recreational trips
- A 50mm suspension front fork combined with wide tires provide extra comfort

**DESCRIPTION** 9-speed Shimano Acera gears with Shimano BR-MT200 hydraulic disc brakes **WEIGHT (KG)** 21,8 (excl. battery) **LBS** 48.1 (excl. battery) **COLOR** champion red or iced blue **LOW-STEP** S(45) | M(50) | L(55) **COLOR** anthracite grey **HIGH-STEP** S(45) | M(50) | L(55)

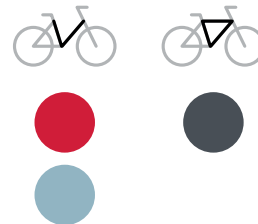

## GAZELLE MEDEO T9 CITY HMB



- Smooth assistance thanks to a Bosch Active Line motor with 40 Nm of torque (20mph) and 400Wh rack battery
- Premium Shimano disc brakes provide smooth and responsive stopping power
- A suspension front fork with 50 mm of travel and wide, puncture-resistant tires offer comfort on mixed road surfaces
- Active geometry combined with a low-step frame creates a fun and lively experience perfectly suited to urban errands and adventures

**DESCRIPTION** 9-speed Shimano Alivio gears with Shimano BR-MT200 hydraulic disc brakes **WEIGHT (KG)** 21,4 (excl. battery) **LBS** 47.2 (excl. battery) **COLOR** light olive or mallard blue **LOW-STEP** S(45) | M(50)





# Avignon

## Modern and comfortable

If you are looking for the ultimate in comfort, search no further than the Avignon. This modern and sturdy e-bike is equipped with all conveniences to make your daily ride as comfortable as possible. And with its sleek design and many integrated components, the Avignon is also an attractive bike. [www.gazellebikes.com/en-us/models/gazelle-avignon](http://www.gazellebikes.com/en-us/models/gazelle-avignon)

## Frame Geometry

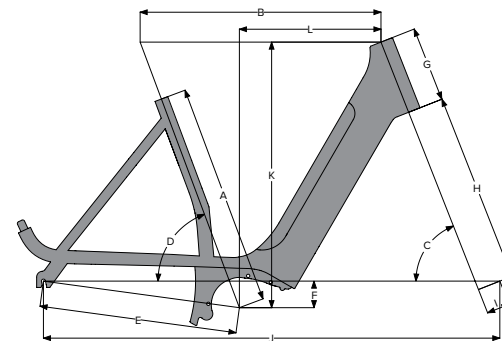

Avignon C380 HMB			
Frame size	S (46)	M (53)	L (57)
<b>A</b> Size (mm)	460	530	570
<b>B</b> Effective top tube length (mm)	595	595	620
<b>C</b> Head tube angle (°)	69	69	69
<b>D</b> Effective seat tube angle (°)	70	70	70
<b>E</b> Chain stay length (mm)	506	506	506
<b>F</b> BB Drop (mm)	68	68	68
<b>G</b> Head tube length (mm)	168	168	193
<b>H</b> Fork length (mm)	484	484	484
<b>I</b> Fork offset (mm)	50	50	50
<b>J</b> Wheelbase (mm)	1137	1137	1162
<b>K</b> Stack (mm)	656	656	680
<b>L</b> Reach (mm)	350	350	366

## GAZELLE AVIGNON C380 HMB



- Powerful support and long lasting range with the Bosch Performance Line motor (75 Nm) providing assistance up to 20 mph with integrated 625 Wh battery
- Powerful daytime running lights with side visibility
- Optimal control thanks to the disc brakes and extra-wide tires
- Use of Enviolo trekking hub means effortless and stepless shifting

**DESCRIPTION** Enviolo Trekking Manual stepless gear system with Magura CT4 hydraulic disc brakes **WEIGHT (KG)** 28,6 (excl. battery) **LBS** 63.1 (excl. battery) **COLOR** pebble grey matte or teal grey matte **LOW-STEP** S(46) | M(53) | L(57)



# Arroyo Elite



## Stable all-rounder

Thanks to the extra powerful and silent Bosch mid-mounted motor, this all-rounder delivers a comfortable cycling experience ideal for day-to-day trips as well as long-distances. Featuring a luxury finish and top-end accessories, this bicycle makes no concessions on quality. The integrated battery frame offers a smart look, and also adds extra stability through the low center of gravity, offering a smooth ride and confident handling. The updated Arroyo comes as standard with a MIK system carrier, so you can outfit your bike with your ideal accessories. [www.gazellebikes.com/en-us/models/gazelle-arroyo](http://www.gazellebikes.com/en-us/models/gazelle-arroyo)

## Frame Geometry

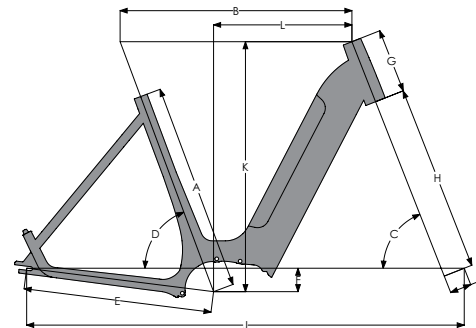

Arroyo Elite HMB			
Frame size, low-step	S (46)	M (53)	L (57)
<b>A</b> Size (mm)	460	530	570
<b>B</b> Effective top tube length (mm)	571	593	605
<b>C</b> Head tube angle (°)	68,5	68,5	68,5
<b>D</b> Effective seat tube angle (°)	69,5	69,5	69,5
<b>E</b> Chain stay length (mm)	482	482	482
<b>F</b> BB Drop (mm)	60	60	60
<b>G</b> Head tube length (mm)	145	165	165
<b>H</b> Fork length (mm)	475	475	475
<b>I</b> Fork offset (mm)	55	55	55
<b>J</b> Wheelbase (mm)	1097	1120	1131
<b>K</b> Stack (mm)	621	640	640
<b>L</b> Reach (mm)	339	354	366



## GAZELLE ARROYO C5 HMB ELITE



- Substantial power and range with the Bosch Performance Line motor (75 Nm) providing support up to 20 mph with integrated 500 Wh battery
- High braking power through hydraulic disc brakes
- Low-maintenance Gates belt drive and special Shimano e-bike internal gear hub
- Leather grips and a sporty comfortable saddle exude luxury

**DESCRIPTION** 5-speed Shimano Nexus gears with Tektro HD-T280 hydraulic disc brakes **WEIGHT (KG)** 24,4 (excl. battery) **LBS** 53.8 (excl. battery) **COLOR** anthracite grey or petrol blue **LOW-STEP** S(46) | M(53) | L(57)



## GAZELLE ARROYO C8 HMB ELITE



- Robust assistance thanks to a Bosch Active Line Plus motor with 50 Nm of torque (20 mph) and 500 Wh integrated in-tube battery
- Lightweight suspension front fork, suspension seat post, and wide, puncture-resistant tires ensure comfort on all road surfaces
- Durable 8-speed Shimano Nexus hub offers smooth shifting
- An iconic design reinvented for modern life on two wheels

**DESCRIPTION** 8-speed Shimano Nexus gears with Tektro HD-T280 hydraulic disc brakes **WEIGHT (KG)** 23,4 (excl. battery) **LBS** 51.6 (excl. battery) **COLOR** black matte or cloud grey **LOW-STEP** S(46) | M(53) | L(57)



## GAZELLE ARROYO C7 HMB ELITE



- Robust assistance thanks to a Bosch Active Line Plus motor with 50 Nm of torque (20 mph) and 500 Wh integrated in-tube battery
- Lightweight suspension front fork, suspension seat post, and wide, puncture-resistant, e-bike-specific tires provide comfort across all conditions
- Reliable 7-speed Shimano Nexus hub
- Responsive Tektro HD-T280 hydraulic disc brakes

**DESCRIPTION** 7-speed Shimano Nexus gears with Tektro HD-T280 hydraulic disc brakes **WEIGHT (KG)** 23,1 (excl. battery) **LBS** 50.9 (excl. battery) **COLOR** frozen white or saturn blue matte **LOW-STEP** S(46) | M(53) | L(57)



## TOUR POPULAIR



- Delightfully relaxed posture
- A robust steel frame with a steel luggage carrier and stainless-steel rims
- Optimum protection against theft thanks to the AXA security lock
- Complete with classic Brooks leather saddle



**DESCRIPTION** 8-speed Shimano Nexus gears with roller brakes **WEIGHT (KG)** 22,9 **LBS** 50.5 **COLOR** black **LOW-STEP** S(51) | M(57)

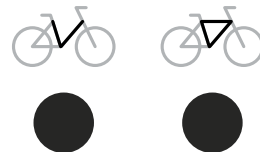

# Accessories



## Do more of life on two wheels

Featuring durable, water-resistant fabrics, sleek designs, and the same quality you would expect from our bikes, our bags allow you to confidently carry cargo in any conditions, and enjoy the ride farther and longer. Gazelle accessories are available for purchase through select Gazelle retailers. [www.gazellebikes.com/en-us/gazelle-accessories](http://www.gazellebikes.com/en-us/gazelle-accessories)

## GAZELLE COMMUTER BAG



The Gazelle commuter bag was designed for getting to work with peace of mind. Everything you need for a day at the office will be well protected in this waterproof bag, including your computer, with a special compartment developed specifically to cushion your laptop; the sleeve fits laptops up to 15 inches. The Gazelle commuter bag has a removable shoulder strap for comfortable carrying off the bike and attachment hooks to ensure the bag is tightly fastened to your bike's rear rack.

- 20L Capacity
- Waterproof fabric
- Reflective elements
- Removable shoulder strap

**DESCRIPTION** Waterproof canvas commuter bag with multiple compartments **CAPACITY** 20L **COLOR** Grey **MOUNTING SYSTEM** Composite hooks **DIMENSIONS** 28 x 43 x 17 cm

## GAZELLE CARRIER BAG



The Gazelle carrier bag is the versatile chameleon in our lineup of accessories. If flexibility is important to you, this MIK-ready rack top-mounted bag offers the ideal setup for your Gazelle, featuring special expandable compartments that dramatically increase your carrying capacity. Even the main compartment can be expanded upwards to provide enough space for your items. Reflective elements on the sides of the bag provide improved visibility, especially in low light conditions, while the water-repellent material and included rain cover will keep your bag's contents dry even in wet weather.

- 31L capacity (with all three compartments expanded)
- Equipped with a rain cover
- Reflective elements all around
- Easy mounting with the MIK-system

**DESCRIPTION** Canvas rack top-mounted bag with multiple expandable compartments **CAPACITY** 31L **COLOR** Black/brown **MOUNTING SYSTEM**  
**MIK DIMENSIONS** 28 x 43 x 17 cm

## GAZELLE DELUXE DOUBLE PANNIER



The Gazelle deluxe double pannier is a luxurious and durable option for carrying serious cargo. With a generous carrying capacity of 39 liters and with a 44 pound weight limit, this accessory handles large loads with ease. Boasting water-repellent material and an integrated MIK-mounting system, this pannier set can stand up to any conditions, from wet weather to rough roads, while multiple reflective stripes enhance visibility and ultimately rider safety. Add a touch of elegance to any errand with this sleek and accommodating accessory.

- 39L capacity
- Easy mounting with the MIK-system
- Water-repellent fabric
- Reinforced sides and bottom

**DESCRIPTION** Two connected water-repellent canvas bags

**CAPACITY** 39L **COLOR** Black **MOUNTING SYSTEM** MIK

**DIMENSIONS** 34 x 16 x 38 cm (2x)



## GAZELLE SINGLE PANNIER



The Gazelle single pannier was developed for leisure and everyday use. With an 18.5 liter capacity, this pannier can handle a small load of groceries, a serious haul from the library, or be used as a shoulder bag for off-bike adventures thanks to an included strap. The bag features a large inner compartment, a smaller lockable outer pocket with a zipper, and a flexible front compartment. Items will stay dry and protected thanks to a water-resistant fabric and hidden rain cover, while composite mounting hooks secure the pannier firmly in place on the rear rack.

- 18.5L Capacity
- Equipped with a rain cover and removable shoulder strap
- Multiple compartments, including a small lockable outer pocket with a zipper
- Removable shoulder strap

**DESCRIPTION** Canvas bag **CAPACITY** 18.5L **COLOR** Black/brown  
**MOUNTING SYSTEM** Composite hooks **DIMENSIONS** 31 x 40 x 15 cm

## GAZELLE DOUBLE PANNIER



The Gazelle double pannier is ideal for errands and adventures large and small. With a carrying capacity of 37 liters, this accessory can handle bulkier loads and support longer trips on two wheels. With functional features such as a water-resistant material and hidden rain covers for each pannier, this practical powerhouse is smart and stylish. Spec'ed with the MIK-mounting system, these bags lock securely to the rear rack, ensuring a safe ride for any and all cargo.

- 37L Capacity
- Easy mounting with the MIK-system
- Water-resistant fabric
- Main compartment, front compartment, and side compartment provide space for all your items

**DESCRIPTION** Two connected canvas bags **CAPACITY** 37L

**COLOR** Black/Olive **MOUNTING SYSTEM** MIK

**DIMENSIONS** 31 x 40 x 15 cm (2x)

# Drop by and discover Gazelle for yourself!

Visit [gazellebikes.com/en-us](https://gazellebikes.com/en-us) to locate your nearest Gazelle dealer and experience the complete line of electric bikes.

## Your Gazelle dealer can offer:

- Individual advice and test rides
- An accurate fit for comfort and pedaling efficiency
- 10 year warranty on every Gazelle frame
- Professional maintenance
- The latest software updates (for electric bikes)
- Original accessories - available for purchase and can be fitted in store

**Come along and find out which Gazelle suits you...**

[gazellebikes.com/en-us](https://gazellebikes.com/en-us)

Please visit our website if you would like further information: [www.gazellebikes.com](https://www.gazellebikes.com). Specifications, texts and illustrations subject to change periodically – printing and typesetting errors sometimes occur. Published by and copyright®: Koninklijke Gazelle N.V., Dieren.

