

User manual

Gazelle with Bosch smart system



Bicycle Owner's Manual

IMPORTANT:

This manual contains important safety, performance and service information. Read it completely before you take the first ride on your new bicycle, and keep it for reference.

Additional safety, performance and service information for specific components such as suspension or pedals on your bicycle, or for accessories such as helmets or lights that you purchase, may also be available. Make sure that your dealer has given you all the manufacturers' literature that was included with your bicycle or accessories. In case of a conflict between the instructions in this manual and information provided by a component manufacturer, always follow the component manufacturer's instructions. You must also read the bpsa manual delivered with this bike.

If you purchased a pedelec, please carefully read the complete original user manual of the pedelec too!

If you have any questions or do not understand something, take responsibility for your safety and consult with your dealer or the bicycle's manufacturer.

NOTE:

This manual is not intended as a comprehensive use, service, repair or maintenance manual. Please see your dealer for all service, repairs or maintenance. Your dealer may also be able to refer you to classes, clinics or books on bicycle use, service, repair or maintenance.

This manual is not intended as a guide to learn how to ride a bicycle or a pedelec.

Content



General warning	4
A special note for parents	5
1 First	6
2 Safety	8
3 Fit	11
4 Tech	13
5 Service	22
Appendix A	24
Appendix B	25
Appendix C	29
Appendix D	29
6 Drive Unit	31
6.1 Drive Unit Performance Line	31
6.2 Drive CX/Cargo/CX Race Edition/Speed	36
7 Display	42
7.1 Kiox 300	42
7.2 Intuvia 100	49
7.3 Purion 200	58
7.4 LED Remote	74
8 Battery	82
PowerTube 500 625 750	82
PowerPack 545 725	82
9 Charger	94



GENERAL WARNING:

Like any sport, bicycling involves risk of injury and damage. By choosing to ride a bicycle, you assume the responsibility for that risk, so you need to know — and to practice — the rules of safe and responsible riding and of proper use and maintenance. Proper use and maintenance of your bicycle reduces risk of injury.

This Manual contains many “Warnings” and “Cautions” concerning the consequences of failure to maintain or inspect your bicycle and of failure to follow safe cycling practices.

- The combination of the  safety alert symbol and the word **WARNING** indicates a potentially hazardous situation which, if not avoided, could result in serious injury or death.
- The combination of the  safety alert symbol and the word **CAUTION** indicates a potentially hazardous situation which, if not avoided, may result in minor or moderate injury, or is an alert against unsafe practices.
- The word **CAUTION** used without the safety alert symbol indicates a situation which, if not avoided, could result in serious damage to the bicycle or the voiding of your warranty.

Many of the Warnings and Cautions say “you may lose control and fall”. Because any fall can result in serious injury or even death, we do not always repeat the warning of possible injury or death.

Because it is impossible to anticipate every situation or condition which can occur while riding, this Manual makes no representation about the safe use of the bicycle under all conditions. There are risks associated with the use of any bicycle which cannot be predicted or avoided, and which are the sole responsibility of the rider.

A special note for parents:

 **WARNING: This manual does not cover children's bikes, Juvenile or BMX bicycles.**

As a parent or guardian, you are responsible for the activities and safety of your minor child, and that includes making sure that the bicycle is properly fitted to the child; that it is in good repair and safe operating condition; that you and your child have learned and understand the safe operation of the bicycle; and that you and your child have learned, understood and obeyed not only the applicable local motor vehicle, bicycle and traffic laws, but also the common sense rules of safe and responsible bicycling. As a parent, you should read this manual, as well as review its warnings and the bicycle's functions and operating procedures with your child, before letting your child ride the bicycle.

 **WARNING: Make sure that your child always wears an approved bicycle helmet when riding; but also make sure that your child understands that a bicycle helmet is for bicycling only, and must be removed when not riding. A helmet must not be worn while playing, in play areas, on playground equipment, while climbing trees, or at any time while not riding a bicycle. Failure to follow this warning could result in serious injury or death.**



1. First

NOTE: We strongly urge you to read this manual in its entirety before your first ride. At the very least, read and make sure that you understand each point in this section, and refer to the cited sections on any issue which you don't completely understand. Please note that not all bicycles have all of the features described in this manual. Ask your dealer to point out the features of your bicycle.

A. Bike fit

1. Is your bike the right size? To check, see Section 3.A. If your bicycle is too large or too small for you, you may lose control and fall. If your new bike is not the right size, ask your dealer to exchange it before you ride it.
2. Is the saddle at the right height? To check, see Section 3.B. If you adjust your saddle height, follow the Minimum Insertion instructions in Section 3.B.
3. Are saddle and seat post securely clamped? A correctly tightened saddle will allow no saddle movement in any direction. See Section 3.B.
4. Are the stem and handlebars at the right height for you? If not, see Section 3.C.
5. Can you comfortably operate the brakes? If not, you may be able to adjust their angle and reach. See Section 3.D and 3.E.
6. Do you fully understand how to operate your new bicycle? If not, before your first ride, have your dealer explain any functions or features which you do not understand.

B. Safety first

1. Always wear an approved and correct fitting helmet when riding your bike, and follow the helmet manufacturer's instructions for fit, use and care.
2. Do you have all the other required and recommended safety equipment? See Section 2. It's your responsibility to familiarize yourself with the laws of the areas where you ride, and to comply with all applicable laws.
3. Do you know how to correctly secure your front and rear wheels? Check Section 4.A.1 to make sure. Riding with an improperly secured wheel can cause the wheel to wobble or disengage from the bicycle, and cause serious injury or death.
4. If your bike has toeclips and straps or clipless ("step-in") pedals, make sure you know how they work (see Section 4.E). These pedals require special techniques and skills. Follow the pedal manufacturer's instructions for use, adjustment and care.
5. Do you have "toe overlap"? On smaller framed bicycles your toe or toeclip may be able to contact the front wheel when a pedal is all the way forward and the wheel is turned. Read Section 4.E. to check whether you have toeclip overlap.
6. Does your bike have suspension? If so, check Section

4.F. Suspension can change the way a bicycle performs. Follow the suspension manufacturer's instructions for use, adjustment and care.

C. Mechanical Safety Check

Routinely check the condition of your bicycle before every ride.

- ▶ **Nuts, bolts screws & other fasteners:** Because manufacturers use a wide variety of fastener sizes and shapes made in a variety of materials, often differing by model and component, the correct tightening force or torque cannot be generalized. To make sure that the many fasteners on your bicycle are correctly tightened, refer to the Fastener Torque Specifications in Appendix D of this manual or to the torque specifications in the instructions provided by the manufacturer of the component in question. Correctly tightening a fastener requires a calibrated torque wrench. A professional bicycle mechanic with a torque wrench should torque the fasteners on your bicycle. If you choose to work on your own bicycle, you must use a torque wrench and the correct tightening torque specifications from the bicycle or component manufacturer or from your dealer. If you need to make an adjustment at home or in the field, we urge you to exercise care, and to have the fasteners you worked on checked by your dealer as soon as possible. *Note that there are some components which require special tools and knowledge. In Sections 3 and 4 we discuss the items which you may be able to adjust yourself. All other adjustments and repairs should be done by a qualified bicycle mechanic.*

 **WARNING: Check all fasteners and quick releases for correct and safe function, even if the bike was left unattended just for a short period of time!**

 **WARNING: Correct tightening force on fasteners – nuts, bolts, screws – on your bicycle is important. Too little force, and the fastener may not hold securely. Too much force, and the fastener can strip threads, stretch, deform or break. Either way, incorrect tightening force can result in component failure, which can cause you to lose control and fall.**

- ▶ Make sure nothing is loose. Lift the front wheel off the ground by two or three inches, then let it bounce on the ground. Anything sound, feel or look loose? Do a visual and tactile inspection of the whole bike. Any loose parts or accessories? If so, secure them. If you're not sure, don't start the ride. First ask someone with experience to check.
- ▶ **Tires & Wheels:** Make sure tires are correctly inflated (see Section 4.G.1). Check by putting one hand on the saddle, one on the intersection of the handlebars and stem, then bouncing your weight on the bike while looking at tire deflection. Compare what you see with how

it looks when you know the tires are correctly inflated; and adjust if necessary.

- ▶ Tires in good shape? Spin each wheel slowly and look for cuts in the tread and sidewall. Replace damaged tires before riding the bike.
- ▶ Wheels true? Spin each wheel and check for brake clearance and side-to-side wobble. If a wheel wobbles side to side even slightly, or rubs against or hits the brake pads, take the bike to a qualified bike shop to have the wheel trued.

 **CAUTION: Wheels must be true for rim brakes to work effectively. Wheel truing is a skill which requires special tools and experience. Do not attempt to true a wheel unless you have the knowledge, experience and tools needed to do the job correctly.**

- ▶ Wheel rims clean and undamaged? Make sure the rims are clean and undamaged at the tire bead and, if you have rim brakes, along the braking surface. Check to make sure that any rim wear indicator marking is not or still visible at any point on the wheel rim depending on the type of wear indicator used on your bike.

 **WARNING: Bicycle wheel rims are subject to wear. Ask your dealer about wheel rim wear. Some wheel rims have a rim wear indicator which becomes visible or disappears as the rim's braking surface wears. A visible rim wear indicator on the side of the wheel rim is an indication that the wheel rim has reached its maximum usable life. Riding a wheel that is at the end of its usable life can result in wheel failure, which can cause you to lose control and fall.**

- ▶ **Brakes:** Check the brakes for proper operation (see Section 4.C). Squeeze the brake levers. Are the brake quick-releases closed? All control cables seated and securely engaged? If you have rim brakes, do the brake pads contact the wheel rim squarely and make full contact with the rim? Do the brakes begin to engage within an inch of brake lever movement? Can you apply full braking force at the levers without having them touch the handlebar? If not, your brakes need adjustment. Do not ride the bike until the brakes are properly adjusted by a professional bicycle mechanic.
- ▶ **Wheel retention system:** Make sure the front and rear wheels are correctly secured. See Section 4.A
- ▶ **Seat post:** If your seat post has an over-center cam action fastener for easy height adjustment, check that it is properly adjusted and in the locked position. See Section 4.B.
- ▶ **Handlebar and saddle alignment:** Make sure the saddle and handlebar stem are parallel to the bike's center line and clamped tight enough so that you can't twist them out of alignment. See Sections 3.B and 3.C.

- ▶ **Handlebar ends:** Make sure the handlebar grips are secure and in good condition, with no cuts, tears, or worn out areas. If not, have your dealer replace them. Make sure the handlebar ends and extensions are plugged. If not, have your dealer plug them before you ride. If the handlebars have bar end extensions, make sure they are clamped tight enough so you can't twist them.

 **WARNING: Loose or damaged handlebar grips or extensions can cause you to lose control and fall. Unplugged handlebars or extensions can cut you and cause serious injury in an otherwise minor accident.**

VERY IMPORTANT SAFETY NOTE:

Please also read and become thoroughly familiar with the important information on the lifespan of your bicycle and its components in Appendix B on Page 28.

D. First ride

When you buckle on your helmet and go for your first familiarization ride on your new bicycle, be sure to pick a controlled environment, away from cars, other cyclists, obstacles or other hazards. Ride to become familiar with the controls, features and performance of your new bike. Familiarize yourself with the braking action of the bike (see Section 4.C). Make yourself familiar which levers activates which brake, right/left, front/rear. Test the brakes at slow speed, putting your weight toward the rear and gently applying the brakes, rear brake first. Sudden or excessive application of the front brake could pitch you over the handlebars. Applying brakes too hard can lock up a wheel, which could cause you to lose control and fall. Skidding is an example of what can happen when a wheel locks up.

If your bicycle has toeclips or clipless pedals, practice getting in and out of the pedals. See paragraph B.4 above and Section 4.E.4.

If your bike has suspension, familiarize yourself with how the suspension responds to brake application and rider weight shifts. See paragraph B.6 above and Section 4.F.

Practice shifting the gears (see Section 4.D). Remember to never move the shifter while pedaling backward, nor pedal backwards immediately after having moved the shifter. This could jam the chain and cause serious damage to the bicycle.

Check out the handling and response of the bike; and check the comfort.

If you have any questions, or if you feel anything about the bike is not as it should be, consult your dealer before you ride again.



2. Safety

A. The Basics

WARNING: The area in which you ride may require specific safety devices. It is your responsibility to familiarize yourself with the laws of the area where you ride and to comply with all applicable laws, including properly equipping yourself and your bike as the law requires.

Observe all local bicycle laws and regulations. Observe regulations about bicycle lighting, licensing of bicycles, riding on sidewalks, laws regulating bike path and trail use, helmet laws, child carrier laws, special bicycle traffic laws. It's your responsibility to know and obey the laws.



1. Always wear a cycling helmet which meets the latest certification standards and is appropriate for the type of riding you do. Always follow the helmet manufacturer's instructions for fit, use and care of your helmet. Most serious bicycle injuries involve head injuries which might have been avoided if the rider had worn an appropriate helmet.

 **WARNING: Failure to wear a helmet when riding may result in serious injury or death.**

2. Always do the Mechanical Safety Check (Section 1.C) before you get on a bike.

3. Be thoroughly familiar with the controls of your bicycle: brakes (Section 4.C.); pedals (Section 4.E.); shifting (Section 4.D.)

4. Be careful to keep body parts and other objects away from the sharp teeth of chainrings, the moving chain, the turning pedals and cranks, and the spinning wheels of your bicycle.

5. Always wear:

- Shoes that will stay on your feet and will grip the pedals. Make sure that shoe laces cannot get into moving parts, and never ride barefoot or in sandals.
- Bright, visible clothing that is not so loose that it can be tangled in the bicycle or snagged by objects at the side of the road or trail.

- Protective eyewear, to protect against airborne dirt, dust and bugs — tinted when the sun is bright, clear when it's not.

6. Unless your bicycle was specifically designed for jumping (See Appendix A, Intended Use) don't jump with your bike. Jumping a bike, particularly a BMX or mountain bike, can be fun; but it can put huge and unpredictable stress on the bicycle and its components. Riders who insist on jumping their bikes risk serious damage, to their bicycles as well as to themselves. Before you attempt to

jump, do stunt riding or race with your bike, read and understand Section 2.F.

7. Ride at a speed appropriate for conditions. Higher speed means higher risk.

B. Riding Safety

1. Obey all Rules of the Road and all local traffic laws.

2. You are sharing the road or the path with others — motorists, pedestrians and other cyclists. Respect their rights.

3. Ride defensively. Always assume that others do not see you.

4. Look ahead, and be ready to avoid:

- Vehicles slowing or turning, entering the road or your lane ahead of you, or coming up behind you.

- Parked car doors opening.
- Pedestrians stepping out.
- Children or pets playing near the road.
- Pot holes, sewer grating, railroad tracks, expansion joints, road or sidewalk construction, debris and other obstructions that could cause you to swerve into traffic, catch your wheel or cause you to have an accident.
- The many other hazards and distractions which can occur on a bicycle ride.

5. Ride in designated bike lanes, on designated bike paths or as close to the edge of the road as possible, in the direction of traffic flow or as directed by local governing laws.

6. Stop at stop signs and traffic lights; slow down and look both ways at street intersections. Remember that a bicycle always loses in a collision with a motor vehicle, so be prepared to yield even if you have the right of way.

7. Use approved hand signals for turning and stopping.

8. Never ride with headphones. They mask traffic sounds and emergency vehicle sirens, distract you from concentrating on what's going on around you, and their wires can tangle in the moving parts of the bicycle, causing you to lose control.

9. Never carry a passenger; and, before installing a child carrier or trailer, check with your dealer or the bicycle manufacturer to make sure the bicycle is designed for it. If the bicycle is suitable for a child carrier or trailer, make sure that the carrier or trailer is correctly mounted and the child is secured and wearing an approved helmet.

10. Never carry anything which obstructs your vision or your complete control of the bicycle, or which could become entangled in the moving parts of the bicycle.

11. Never hitch a ride by holding on to another vehicle.

12. Don't do stunts, wheelies or jumps. If you intend to do stunts, wheelies, jumps or go racing with your bike despite our advice not to, read Section 2.F, *Downhill, Stunt or Competition Biking*, now. Think carefully about your skills before deciding to take the large risks that go with this kind of riding.

13. Don't weave through traffic or make any moves that

may surprise people with whom you are sharing the road.

14. Observe and yield the right of way.

15. Never ride your bicycle while under the influence of alcohol or drugs.

16. If possible, avoid riding in bad weather, when visibility is obscured, at dawn, dusk or in the dark, or when extremely tired. Each of these conditions increases the risk of accident.

C. Off Road Safety

We recommend that children do not ride on rough terrain unless they are accompanied by an adult.

1. The variable conditions and hazards of off-road riding require close attention and specific skills. Start slowly on easier terrain and build up your skills. If your bike has suspension, the increased speed you may develop also increases your risk of losing control and falling. Get to know how to handle your bike safely before trying increased speed or more difficult terrain.

2. Wear safety gear like a helmet and protectors appropriate to the kind of riding you plan to do.

3. Don't ride alone in remote areas. Even when riding with others, make sure that someone knows where you're going and when you expect to be back.

4. Always take along some kind of identification, so that people know who you are in case of an accident; and take along some cash for food, a cool drink or an emergency phone call.

5. Yield right of way to pedestrians and animals. Ride in a way that does not frighten or endanger them, and give them enough room so that their unexpected moves don't endanger you.

6. Be prepared. If something goes wrong while you're riding off-road, help may not be close.

7. Before you attempt to jump, do stunt riding or race with your bike, read and understand Section 2.F.

Off Road respect

Obey the local laws regulating where and how you can ride off-road, and respect private property. You may be sharing the trail with others — hikers, equestrians, other cyclists. Respect their rights. Stay on the designated trail. Don't contribute to erosion by riding in mud or with unnecessary sliding. Don't disturb the ecosystem by cutting your own trail or shortcut through vegetation or streams. It is your responsibility to minimize your impact on the environment. Leave things as you found them; and always take out everything you brought in.

D. Wet Weather Riding

 **WARNING: Wet weather impairs traction, braking and visibility, both for the bicyclist and for other vehicles sharing the road. The risk of an accident is dramatically increased in wet conditions.**

Under wet conditions, the stopping power of your brakes (as well as the brakes of other vehicles sharing the road) is dramatically reduced and your tires don't grip nearly as well. This makes it harder to control speed and easier to lose control. To make sure that you can slow down and stop safely in wet conditions, ride more slowly and apply your brakes earlier and more gradually than you would under normal, dry conditions. See also Section 4.C.

E. Night Riding

Riding a bicycle at night is *much* more dangerous than riding during the day. A bicyclist is very difficult for motorists and pedestrians to see. Therefore, children should never ride at dawn, at dusk or at night. Adults who chose to accept the greatly increased risk of riding at dawn, at dusk or at night need to take extra care both riding and choosing specialized equipment which helps reduce that risk. Consult your dealer about night riding safety equipment.

 **WARNING: Reflectors are not a substitute for required lights. Riding at dawn, at dusk, at night or at other times of poor visibility without an adequate bicycle lighting system and without reflectors is dangerous and may result in serious injury or death.**

Bicycle reflectors are designed to pick up and reflect car lights and street lights in a way that may help you to be seen and recognized as a moving bicyclist.

 **CAUTION: Check reflectors and their mounting brackets regularly to make sure that they are clean, straight, unbroken and securely mounted. Have your dealer replace damaged reflectors and straighten or tighten any that are bent or loose.**

The mounting brackets of front and rear reflectors are often designed as brake straddle cable safety catches which prevent the straddle cable from catching on the tire tread if the cable jumps out of its yoke or breaks.

 **WARNING: Do not remove the front or rear reflectors or reflector brackets from your bicycle. They are an integral part of the bicycle's safety system.**

Removing the reflectors reduces your visibility to others using the roadway. Being struck by other vehicles may result in serious injury or death.

The reflector brackets may protect you from a brake straddle cable catching on the tire in the event of brake cable failure. If a brake straddle cable catches on the tire, it can cause the wheel to stop suddenly, causing you to lose control and fall.



If you choose to ride under conditions of poor visibility, check and be sure you comply with all local laws about night riding, and take the following strongly recommended additional precautions:

- Purchase and install battery or generator powered head and tail lights which meet all regulatory requirements for where you live and provide adequate visibility.
- Wear light colored, reflective clothing and accessories, such as a reflective vest, reflective arm and leg bands, reflective stripes on your helmet, flashing lights attached to your body and/or your bicycle ... any reflective device or light source that moves will help you get the attention of approaching motorists, pedestrians and other traffic.
- Make sure your clothing or anything you may be carrying on the bicycle does not obstruct a reflector or light.
- Make sure that your bicycle is equipped with correctly positioned and securely mounted reflectors.

While riding at dawn, at dusk or at night:

- Ride slowly.
 - Avoid dark areas and areas of heavy or fast-moving traffic.
 - Avoid road hazards.
 - If possible, ride on familiar routes.
- If riding in traffic:
- Be predictable. Ride so that drivers can see you and predict your movements.
 - Be alert. Ride defensively and expect the unexpected.
 - If you plan to ride in traffic often, ask your dealer about traffic safety classes or a good book on bicycle traffic safety.

F. Extreme, stunt or competition riding

Whether you call it *Aggro*, *Hucking*, *Freeride*, *North Shore*, *Downhill*, *Jumping*, *Stunt Riding*, *Racing* or something else: if you engage in this sort of extreme, aggressive riding you **will get hurt**, and you voluntarily assume a greatly increased risk of injury or death.

Not all bicycles are designed for these types of riding, and those that are may not be suitable for all types of aggressive riding. Check with your dealer or the bicycle's manufacturer about the suitability of your bicycle before engaging in extreme riding.

When riding fast down hill, you can reach speeds achieved by motorcycles, and therefore face similar hazards and risks. Have your bicycle and equipment carefully inspected by a qualified mechanic and be sure it is in perfect condition. Consult with expert riders, area site personnel and race officials on conditions and equipment advisable at the site where you plan to ride. Wear appropriate safety gear, including an approved full face helmet, full finger gloves, and body armor. Ultimately, it is your responsibility to have proper equipment and to

be familiar with course conditions.

 **WARNING: Although many catalogs, advertisements and articles about bicycling depict riders engaged in extreme riding, this activity is extremely dangerous, increases your risk of injury or death, and increases the severity of any injury. Remember that the action depicted is being performed by professionals with many years of training and experience. Know your limits and always wear a helmet and other appropriate safety gear. Even with state-of-the-art protective safety gear, you could be seriously injured or killed when jumping, stunt riding, riding downhill at speed or in competition.**

 **WARNING: Bicycles and bicycle parts have limitations with regard to strength and integrity, and this type of riding can exceed those limitations or dramatically reduce the length of their safe use.**

We recommend against this type of riding because of the increased risks; but if you choose to take the risk, at least:

- Take lessons from a competent instructor first
- Start with easy learning exercises and slowly develop your skills before trying more difficult or dangerous riding
- Use only designated areas for stunts, jumping, racing or fast downhill riding
- Wear a full face helmet, safety pads and other safety gear
- Understand and recognize that the stresses imposed on your bike by this kind of activity may break or damage parts of the bicycle and void the warranty
- Take your bicycle to your dealer if anything breaks or bends. Do not ride your bicycle when any part is damaged.

If you ride downhill at speed, do stunt riding or ride in competition, know the limits of your skill and experience. Ultimately, avoiding injury is your responsibility.

G. Changing Components or Adding Accessories

There are many components and accessories available to enhance the comfort, performance and appearance of your bicycle. However, if you change components or add accessories, you do so at your own risk. The bicycle's manufacturer may not have tested that component or accessory for compatibility, reliability or safety on your bicycle. Before installing any component or accessory, including but not limited to a different size tire, a lighting system, a luggage rack, a child seat, a trailer, etc., make sure that it is compatible with your bicycle by checking with your dealer. Be sure to read, understand and follow the instructions that accompany the products you purchase for your bicycle. See also *Appendix A*, p. 24 and *B*, p. 28.

 **WARNING: Failure to confirm compatibility, properly install, operate and maintain any component or accessory can result in serious injury or death.**

 **WARNING: Exposed springs on the saddle of any bicycle fitted with a child seat can cause serious injury to the child. Cover all springs of the saddle and the seatpost to avoid that the child can get hurt.**

 **WARNING: Changing the components on your bike with other than genuine replacement parts may compromise the safety of your bicycle and may void the warranty. Check with your dealer before changing the components on your bike.**

3. Fit

NOTE: Correct fit is an essential element of bicycling safety, performance and comfort. Making the adjustments to your bicycle which result in correct fit for your body and riding conditions requires experience, skill and special tools. Always have your dealer make the adjustments on your bicycle; or, if you have the experience, skill and tools, have your dealer check your work before riding.

 **WARNING: If your bicycle does not fit properly, you may lose control and fall. If your new bike doesn't fit, ask your dealer to exchange it before you ride it.**

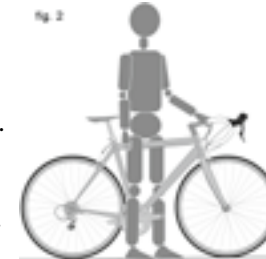

A. Standover height

1. Diamond frame bicycles

Standover height is the basic element of bike fit (see). It is the distance from the ground to the top of the bicycle's frame at that point where your crotch is when straddling the bike. To check for correct standover height, straddle the bike while wearing the kind of shoes in which you'll be riding, and bounce vigorously on your heels. If your crotch touches the frame, the bike is too big for you. Don't even ride the bike around the block. A bike which you ride only on paved surfaces and never take off-road should give you a minimum standover height clearance of two inches (5 cm). A bike that you'll ride on unpaved surfaces should give you a minimum of three inches (7.5 cm) of standover height clearance. And a bike that you'll use off road should give you four inches (10 cm) or more of clearance.

2. Step-through frame bicycles

Standover height does not apply to bicycles with step-through frames. Instead, the limiting dimension is determined by saddle height range. You must be able to adjust your saddle position as described in **B** without exceeding the limits set by the height of the top of the seat tube and the "Minimum Insertion" or "Maximum Extension" mark on the seat post.

B. Saddle position

Correct saddle adjustment is an important factor in getting the most performance and comfort from your bicycle. If the saddle position is not comfortable for you, see your dealer.

The saddle can be adjusted in three directions:

1. Up and down adjustment.

To check for correct saddle height (fig. 3):

- sit on the saddle;
- place one heel on a pedal;
- rotate the crank until the pedal with your heel on it is in the down position and the crank arm is vertical.



If your leg is not completely straight, your saddle height needs to be adjusted. If your hips must rock for the heel to reach the pedal, the saddle is too high. If your leg is bent at the knee with your heel on the pedal, the saddle is too low.

Ask your dealer to set the saddle for your optimal riding position and to show you how to make this adjustment.

If you choose to make your own saddle height adjustment:

- ▶ loosen the seat post clamp
- ▶ raise or lower the seat post in the seat tube
- ▶ make sure the saddle is straight fore and aft
- ▶ re-tighten the seat post clamp to the recommended torque (Appendix D or the manufacturer's instructions).



Once the saddle is at the correct height, make sure that the seat post does not project from the frame beyond its "Minimum Insertion" or "Maximum Extension" mark (fig. 4).



NOTE: Some bicycles have a sight hole in the seat tube, the purpose of which is to make it easy to see whether the seat post is inserted in the seat tube far enough to be safe. If your bicycle has such a sight hole, use it instead of the “Minimum Insertion” or “Maximum Extension” mark to make sure the seat post is inserted in the seat tube far enough to be visible through the sight hole.

If your bike has an interrupted seat tube, as is the case on some suspension bikes, you must also make sure that the seat post is far enough into the frame so that you can touch it through the bottom of the interrupted seat tube with the tip of your finger without inserting your finger beyond its first knuckle. In case of an interrupted seat tube you must take care, that the seat post never touches the suspension element or another part of the frame, no matter how much the suspension element is compressed!
Also see NOTE above and fig. 5).



WARNING: If your seat post is not inserted in the seat tube as described in B.1 above, the seat post, binder or even frame may break, which could cause you to lose control and fall.

2. Front and back adjustment. The saddle can be adjusted forward or back to help you get the optimal position on the bike. Ask your dealer to set the saddle for your optimal riding position and to show you how to make this adjustment. If you choose to make your own front and back adjustment, make sure that the clamp mechanism is clamping on the straight part of the saddle rails and is not touching the curved part of the rails, and that you are using the recommended torque on the clamping fastener(s) (Appendix D or the manufacturer's instructions).

3. Saddle angle adjustment. Most people prefer a horizontal saddle; but some riders like the saddle nose angled up or down just a little. Your dealer can adjust saddle angle or teach you how to do it. If you choose to make your own saddle angle adjustment and you have a single bolt saddle clamp on your seat post, it is critical that you loosen the clamp bolt sufficiently to allow any serrations on the mechanism to disengage before changing the saddle's angle, and then that the serrations fully re-engage before you tighten the clamp bolt to the recommended torque (Appendix D or the manufacturer's instructions).

WARNING: When making saddle angle adjustments with a single bolt saddle clamp, always check to make sure that the serrations on the mating surfaces of the clamp are not worn. Worn serrations on the clamp can allow the saddle to move, causing you to lose control and fall.

Always tighten fasteners to the correct torque. Bolts that are too tight can stretch and deform. Bolts that are too loose can move and fatigue. Either mistake can lead to a sudden failure of the bolt, causing you to lose control and fall.

Note: If your bicycle is equipped with a suspension seat post, the suspension mechanism may require periodic service or maintenance. Ask your dealer for recommended service intervals for your suspension seat post.

Small changes in saddle position can have a substantial effect on performance and comfort. To find your best saddle position, make only one adjustment at a time.

WARNING: After any saddle adjustment, be sure that the saddle adjusting mechanism is properly seated and tightened before riding. A loose saddle clamp or seat post clamp can cause damage to the seat post, or can cause you to lose control and fall. A correctly tightened saddle adjusting mechanism will allow no saddle movement in any direction. Periodically check to make sure that the saddle adjusting mechanism is properly tightened.

If, in spite of carefully adjusting the saddle height, tilt and fore-and-aft position, your saddle is still uncomfortable, you may need a different saddle design. Saddles, like people, come in many different shapes, sizes and resilience. Your dealer can help you select a saddle which, when correctly adjusted for your body and riding style, will be comfortable.

WARNING: Some people have claimed that extended riding with a saddle which is incorrectly adjusted or which does not support your pelvic area correctly can cause short-term or long-term injury to nerves and blood vessels, or even impotence. If your saddle causes you pain, numbness or other discomfort, listen to your body and stop riding until you see your dealer about saddle adjustment or a different saddle.

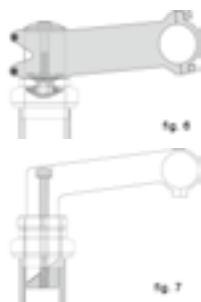

C. Handlebar height and angle

Your bike is equipped either with a “threadless” stem, which clamps on to the outside of the fork shaft, or with a “quill” stem, which clamps inside the steerer tube by way of an expanding binder bolt. If you aren't absolutely sure which type of stem your bike has, ask your dealer.

If your bike has a “threadless” stem (fig. 6) your dealer may be able to change handlebar height by moving height adjustment spacers from below the stem to above the stem, or vice versa. Otherwise, you'll have to get a stem of different length or rise. Consult your dealer. Do not attempt to do this yourself, as it requires special knowledge.

If your bike has a “quill” stem on its shaft which designates the stem's “Minimum Insertion” or “Maximum Extension”. This mark must not be visible above the headset.

WARNING: A quill stem's Minimum Insertion Mark must not be visible above the top of the headset. If the stem is extended beyond the Minimum Insertion Mark the stem may break or damage the fork's steerer tube, which could cause you to lose control and fall.

WARNING: On some bicycles, changing the stem or stem height can affect the tension of the front brake cable, locking the front brake or creating excess cable slack which can make the brakes and the shifters inoperable. If the brake pads move in towards the wheel rim or out away from the wheel rim when the stem or stem height is changed, the brakes must be correctly adjusted before you ride the bicycle.

Some bicycles are equipped with an adjustable angle stem. If your bicycle has an adjustable angle stem, ask your dealer to show you how to adjust it. Do not attempt to make the adjustment yourself, as changing stem angle may also require adjustments to the bicycle's controls.

WARNING: Always tighten fasteners to the correct torque. Bolts that are too tight can stretch and deform. Bolts that are too loose can move and fatigue. Either mistake can lead to a sudden failure of the bolt, causing you to lose control and fall.

Your dealer can also change the angle of the handlebar or bar end extensions.

WARNING: An insufficiently tightened stem clamp bolt, handlebar clamp bolt or bar end extension clamping bolt may compromise steering action, which could cause you to lose control and fall. Place the front wheel of the bicycle between your legs and attempt to twist the handlebar/stem assembly. If you can twist the stem in relation to the front wheel, turn the handlebars in

relation to the stem, or turn the bar end extensions in relation to the handlebar, the bolts are insufficiently tightened.

WARNING: Be aware that adding aerodynamic extensions to handlebars will change the steering and braking response of the bicycle.

D. Control position adjustments

The angle of the brake and shift control levers and their position on the handlebars can be changed. Ask your dealer to make the adjustments for you. If you choose to make your own control lever angle adjustment, be sure to re-tighten the clamp fasteners to the recommended torque (Appendix D or the manufacturer's instructions).

E. Brake reach

Many bikes have brake levers which can be adjusted for reach. If you have small hands or find it difficult to squeeze the brake levers, your dealer can either adjust the reach or fit shorter reach brake levers.

WARNING: The shorter the brake lever reach, the more critical it is to have correctly adjusted brakes, so that full braking power can be applied within available brake lever travel. Make sure, that the brake levers never touches the handlebar or the grips, no matter how hard you pull them. Brake lever travel insufficient to apply full braking power can result in loss of control, which may result in serious injury or death.

4. Tech

It's important to your safety, performance and enjoyment to understand how things work on your bicycle. We urge you to ask your dealer how to do the things described in this section before you attempt them yourself, and that you have your dealer check your work before you ride the bike. If you have even the slightest doubt as to whether you understand something in this section of the Manual, talk to your dealer. See also Appendix A, B, C and D.

A. Wheels

Bicycle wheels are designed to be removable for easier transportation and for repair of a tire puncture. In most cases, the wheel axles are inserted into slots, called “dropouts” in the fork and frame, but some mountain and road bikes use what is called a “through axle” wheel mounting system.



If you have a mountain or road bike equipped with through axle front or rear wheels, make sure that your dealer has given you the manufacturer's instructions, and follow those when installing or removing a through axle wheel. If you don't know what a through axle is, ask your dealer.

If you do not have a bicycle with a through-axle wheel mounting system, it will have wheels secured in one of three ways:

- A hollow axle with a shaft ("skewer") running through it which has an adjustable tension nut on one end and an over-center cam on the other (cam action system, fig.8 a & b)

- A hollow axle with a shaft ("skewer") running through it which has a nut on one end and a fitting for a hex key, lock lever or other tightening device on the other (through bolt, fig. 9)

- Hex nuts or hex key bolts which are threaded on to or into the hub axle (bolt-on wheel, fig. 10)

Your bicycle may be equipped with a different securing method for the front wheel than for the rear wheel.

Discuss the wheel securing method for your bicycle with your dealer.



It is very important that you understand the type of wheel securing method on your bicycle, that you know how to secure the wheels correctly, and that you know how to apply the correct clamping force that safely secures the wheel. Ask your dealer to instruct you in correct wheel removal and installation, and ask him to give you any available manufacturer's instructions.

WARNING: Riding with an improperly secured wheel can allow the wheel to wobble or fall off the bicycle, which can cause serious injury or death. Therefore, it is essential that you:

1. Ask your dealer to help you make sure you know how to install and remove your wheels safely.

2. Understand and apply the correct technique for clamping your wheel in place.

3. Each time, before you ride the bike, check that the wheel is securely clamped.

The clamping action of a correctly secured wheel must emboss the surfaces of the dropouts.

1. Front Wheel Secondary Retention Devices

Most bicycles have front forks which utilize a secondary wheel retention device to reduce the risk of the wheel disengaging from the fork if the wheel is incorrectly secured. Secondary retention devices are not a substitute for correctly securing your front wheel.

Secondary retention devices fall into two basic categories:

- a. The clip-on type is a part which the manufacturer adds to the front wheel hub or front fork.

- b. The integral type is molded, cast or machined into the outer faces of the front fork dropouts.

Ask your dealer to explain the particular secondary retention device on your bike.

WARNING: Do not remove or disable the secondary retention device. As its name implies, it serves as a back-up for a critical adjustment. If the wheel is not secured correctly, the secondary retention device can reduce the risk of the wheel disengaging from the fork. Removing or disabling the secondary retention device may also void the warranty.

Secondary retention devices are not a substitute for correctly securing your wheel. Failure to properly secure the wheel can cause the wheel to wobble or disengage, which could cause you to lose control and fall, resulting in serious injury or death.

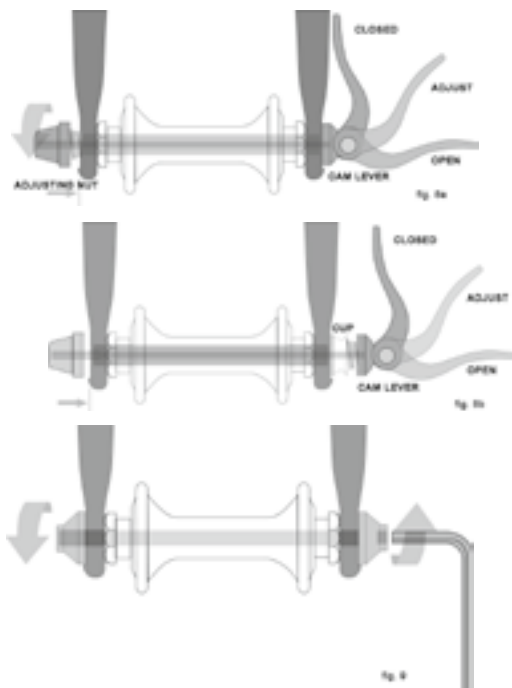

2. Wheels with cam action systems

There are currently two types of over-center cam wheel retention mechanisms: the traditional over-center cam (fig. 8a) and the cam-and-cup system (fig. 8b). Both use an over-center cam action to clamp the bike's wheel in place. Your bicycle may have a cam-and-cup front wheel retention system and a traditional rear wheel cam action system.

a. Adjusting the traditional cam action mechanism (fig. 8a)

The wheel hub is clamped in place by the force of the over-center cam pushing against one dropout and pulling the tension adjusting nut, by way of the skewer, against the other dropout. The amount of clamping force is controlled by the tension adjusting nut. Turning the tension adjusting nut clockwise while keeping the opened cam lever from rotating increases clamping force; turning it counterclockwise while keeping the opened cam lever from rotating reduces clamping force. Less than half a turn of the tension adjusting nut can make the difference between safe clamping force and unsafe clamping force.

WARNING: The full force of the cam action is needed to clamp the wheel securely. Holding the nut with one hand and turning the lever like a wing nut with the other hand until everything is as tight as you can get it will not clamp a cam action wheel safely in the dropouts. See also the first WARNING in this Section, p. 18.

b. Adjusting the cam-and-cup mechanism (fig. 8b)

The cam-and-cup system on your front wheel will have been correctly adjusted for your bicycle by your dealer. Ask your dealer to check the adjustment every six months. Do not use a cam-and-cup front wheel on any bicycle other than the one for which your dealer adjusted it.

3. Removing and Installing wheels

WARNING: If your bike is equipped with a hub brake such as a rear coaster brake, front or rear drum, band or roller brake; or if it has an internal gear rear hub, do not attempt to remove the wheel. The removal and re-installation of most hub brakes and internal gear hubs requires special knowledge. Incorrect removal or assembly can result in brake or gear failure, which can cause you to lose control and fall.

CAUTION: If your bike has a disc brake, exercise care in touching the rotor or caliper. Disc rotors have sharp edges, and both rotor and caliper can get very hot during use.

a. Removing a disk brake or rim brake Front Wheel

- (1) If your bike has rim brakes, disengage the brake's quick-release mechanism to increase the clearance between the tire and the brake pads (See Section 4.C fig. 11 through 15).

- (2) If your bike has cam action front wheel retention, move the cam lever from the locked or CLOSED position to the OPEN position (figs. 8a & b). If your bike has through bolt or bolt-on front wheel retention, loosen the fastener(s) a few turns counter-clockwise using an appropriate wrench, lock key or the integral lever.

- (3) If your front fork has a clip-on type secondary retention device, disengage it. If your front fork has an integral secondary retention device, and a traditional cam action system (fig. 8a) loosen the tension adjusting nut enough to allow removing the wheel from the dropouts. If your front wheel uses a cam-and-cup system, (fig. 8b) squeeze the cup and cam lever together while removing the wheel. No rotation of any part is necessary with the cam-and-cup system.

You may need to tap the top of the wheel with the palm of your hand to release the wheel from the front fork.

b. Installing a disk brake or rim brake Front Wheel

CAUTION: If your bike is equipped with a front disk brake, be careful not to damage the disk, caliper or brake pads when re-inserting the disk into the caliper. Never activate a disk brake's control lever unless the disk is correctly inserted in the caliper and the bike is in an upright position. See also Section 4.C.

- (1) If your bike has cam action front wheel retention, move the cam lever so that it curves away from the wheel (fig. 8b). This is the OPEN position. If your bike has through bolt or bolt-on front wheel retention, go to the next step. Make sure that the brake disc is positioned on the correct side so it can fit in the caliper.

- (2) With the steering fork facing forward, insert the wheel between the fork blades so that the axle seats firmly at the top of the fork dropouts. The cam lever, if there is one, should be on rider's left side of the bicycle (fig. 8a & b). If your bike has a clip-on type secondary retention device, engage it.

- (3) If you have a traditional cam action mechanism: holding the cam lever in the ADJUST position with your right hand, tighten the tension adjusting nut with your left hand until it is finger tight against the fork dropout (fig. 8a). If you have a cam-and-cup system: the nut and cup (fig. 8b) will have snapped into the recessed area of the fork dropouts and no adjustment should be required.
- (4) While pushing the wheel firmly to the top of the slots in the fork dropouts, and at the same time centering the wheel rim in the fork:

- (a) With a cam action system, move the cam lever upwards and swing it into the CLOSED position (fig. 8a & b). The lever should now be parallel to the fork blade and curved toward the wheel. It should point backwards to avoid being opened by contact while riding. To apply enough clamping force, you should have to wrap your fingers around the fork blade for leverage, and the lever



should leave a clear imprint in the palm of your hand.

(b) With a through-bolt or bolt-on system, tighten the fasteners to the torque specifications in Appendix D or the hub manufacturer's instructions.

NOTE: If, on a traditional cam action system, the lever cannot be pushed all the way to a position parallel to the fork blade, return the lever to the OPEN position. Then turn the tension adjusting nut counterclockwise one-quarter turn and try tightening the lever again.

D (6) With a through-bolt or bolt-on system, tighten the fasteners to the torque specifications in Appendix D or the hub manufacturer's instructions.

 **WARNING: Securely clamping the wheel with a cam action retention device takes considerable force. If you can fully close the cam lever without wrapping your fingers around the fork blade for leverage, the lever does not leave a clear imprint in the palm of your hand, and the serrations on the wheel fastener do not emboss the surfaces of the dropouts, the tension is insufficient. Open the lever; turn the tension adjusting nut clockwise a quarter turn; then try again. See also the first WARNING in this Section, p. 18.**

(6) If you disengaged the brake quick-release mechanism in 3. a. (1) above, re-engage it to restore correct brake pad-to-rim clearance.

(7) Spin the wheel to make sure that it is centered in the frame and clears the brake pads; then squeeze the brake lever and make sure that the brakes are operating correctly.

c. Removing a disk brake or rim brake Rear Wheel

(1) If you have a multi-speed bike with a derailleur gear system: shift the rear derailleur to high gear (the smallest, outermost rear sprocket).

If you have an internal gear rear hub, consult your dealer or the hub manufacturer's instructions before attempting to remove the rear wheel.

If you have a single-speed bike with rim or disk brake, go to step (4) below.

(2) If your bike has rim brakes, disengage the brake's quick-release mechanism to increase the clearance between the wheel rim and the brake pads (see Section 4.C, figs. 11 through 15).

(3) On a derailleur gear system, pull the derailleur body back with your right hand.

(4) With a cam action mechanism, move the quick-release lever to the OPEN position (fig. 8b). With a through bolt or bolt on mechanism, loosen the fastener(s) with an appropriate wrench, lock lever or integral lever; then push the wheel forward far enough to be able to remove the chain from the rear sprocket.

(5) Lift the rear wheel off the ground a few inches and

remove it from the rear dropouts.

d. Installing a disk brake or rim brake Rear Wheel

 **CAUTION: If your bike is equipped with a rear disk brake, be careful not to damage the disk, caliper or brake pads when re-inserting the disk into the caliper. Never activate a disk brake's control lever unless the disk is correctly inserted in the caliper and the bike is in an upright position.**

(1) With a cam action system, move the cam lever to the OPEN position (see fig. 8 a & b). The lever should be on the side of the wheel opposite the derailleur and freewheel sprockets.

(2) On a derailleur bike, make sure that the rear derailleur is still in its outermost, high gear, position; then pull the derailleur body back with your right hand. Put the upper part of the chain on top of the smallest freewheel sprocket.

(3) On single-speed or an internal gear hub, remove the chain from the front sprocket, so that you have plenty of slack in the chain. Put the chain on the rear wheel sprocket.

(4) Then, insert the wheel into the frame dropouts and pull it all the way in to the dropouts. Make sure that the brake disc fits correctly in the caliper.

(5) On a single speed or an internal gear hub, replace the chain on the chainring; pull the wheel back in the dropouts so that it is straight in the frame and the chain has about 1/4 inches of up-and-down play.

(6) With a cam action system, move the cam lever upwards and swing it into the CLOSED position (fig. 8 a & b). The lever should now be parallel to the seat stay or pointing backwards and curved toward the wheel. To apply enough clamping force, you should have to wrap your fingers around the fork blade for leverage, and the lever should leave a clear imprint in the palm of your hand.

(7) With a through-bolt or bolt-on system, tighten the fasteners to the torque specifications in Appendix D or the hub manufacturer's instructions.

NOTE: If, on a traditional cam action system, the lever cannot be pushed all the way to a position parallel to the seat stay, return the lever to the OPEN position. Then turn the tension adjusting nut counterclockwise one-quarter turn and try tightening the lever again.

 **WARNING: Securely clamping the wheel with a cam action retention device takes considerable force. If you can fully close the cam lever without wrapping your fingers around the seat stay or chain stay for leverage, the lever does not leave a clear imprint in the palm of your hand, and the serrations on the wheel**

fastener do not emboss the surfaces of the dropouts, the tension is insufficient. Open the lever; turn the tension adjusting nut clockwise a quarter turn; then try again.

(8) If you disengaged the brake quick-release mechanism in 3. c. (2) above, re-engage it to restore correct brake pad-to-rim clearance.

(9) Spin the wheel to make sure that it is centered in the frame and clears the brake pads; then squeeze the brake lever and make sure that the brakes are operating correctly.

B. Seat post cam action clamp

Some bikes are equipped with a cam action seat post binder. The seat post cam action binder works exactly like the traditional wheel cam action fastener (Section 4.A.2) While a cam action binder looks like a long bolt with a lever on one end and a nut on the other, the binder uses an over-center cam action to firmly clamp the seat post (see fig. 8a).

 **WARNING: Riding with an improperly tightened seat post can allow the saddle to turn or move and cause you to lose control and fall. Therefore:**

1. Ask your dealer to help you make sure you know how to correctly clamp your seat post.
2. Understand and apply the correct technique for clamping your seat post.
3. Before you ride the bike, first check that the seat post is securely clamped.

Adjusting the seat post cam action mechanism

The action of the cam squeezes the seat collar around the seat post to hold the seat post securely in place. The amount of clamping force is controlled by the tension adjusting nut. Turning the tension adjusting nut clockwise while keeping the cam lever from rotating increases clamping force; turning it counterclockwise while keeping the cam lever from rotating reduces clamping force. Less than half a turn of the tension adjusting nut can make the difference between safe and unsafe clamping force.

 **WARNING: Especially if components (seat post, frame) made of composites like carbon fibre are in use, never overtighten the seat post clamp! Composites and carbon fibre require a different clamping force. Read the manufacturers manual for correct use.**

 **WARNING: The full force of the cam action is needed to clamp the seat post securely. Holding the nut with one hand and turning the lever like a wing nut with the other hand until everything is as tight as you can get it will not clamp the seat post safely.**

 **WARNING: If you can fully close the cam lever without wrapping your fingers around the seat post or a frame tube for leverage, and the lever does not leave a clear imprint in the palm of your hand, the tension is insufficient. Open the lever; turn the tension adjusting nut clockwise a quarter turn; then try again.**

C. Brakes

There are three general types of bicycle brakes: rim brakes, which operate by squeezing the wheel rim between two brake pads; disc brakes, which operate by squeezing a hub-mounted disc between two brake pads; and internal hub brakes. All three can be operated by way of a handlebar mounted lever. On some models of bicycle, the internal hub brake is operated by pedaling backwards. This is called a Coaster Brake and is described in Appendix C.

 **WARNING:**
1. Riding with improperly adjusted brakes, worn brake pads, or wheels on which the rim wear mark is visible or invisible because of rim wear is dangerous and can result in serious injury or death.

2. Applying brakes too hard or too suddenly can lock up a wheel, which could cause you to lose control and fall. Sudden or excessive application of the front brake may pitch the rider over the handlebars, which may result in serious injury or death.

3. Some bicycle brakes, such as disc brakes (fig. 11) and linear-pull brakes (fig. 12), are extremely powerful. Take extra care in becoming familiar with these brakes and exercise particular care when using them.

4. Some bicycle brakes are equipped with a brake force modulator, a small, cylindrical device through which the brake control cable runs and which is designed to provide a more progressive application of braking force. A modulator makes the initial brake lever force more gentle, progressively increasing force until full force is achieved. If your bike is equipped with a brake force modulator, take extra care in becoming familiar with its performance characteristics. Some brake force modulators are adjustable. If you don't like the feel of your brakes, ask your dealer about adjusting the brake force modulation.

5. Disc brakes can get extremely hot with extended use. Be careful not to touch a disc brake until it has had plenty of time to cool.

6. See the brake manufacturer's instructions for operation and care of your brakes, and for when brake pads must be replaced. If you do not have the manufacturer's instructions, see your dealer or contact the brake manufacturer.

7. If replacing worn or damaged parts, use only manufacturer-approved genuine replacement parts.



1. Brake controls and features

It's very important to your safety that you learn and remember which brake lever controls which brake on your bike. Traditionally, in the U.S. the right brake lever controls the rear brake and the left brake lever controls the front brake; but, to check how your bike's brakes are set up, squeeze one brake lever and look to see which brake, front or rear, engages. Now do the same with the other brake lever.

Make sure that your hands can reach and squeeze the brake levers comfortably. If your hands are too small to operate the levers comfortably, consult your dealer before riding the bike. The lever reach may be adjustable; or you may need a different brake lever design.

Most rim brakes have some form mechanism to allow the brake pads a wheel is removed or reinstalled. When the brake quick release is in the open position, the brakes are inoperative. Ask your dealer to make sure that you understand the way the brake quick release works on your bike (see figs. 12, 13, 14 & 15) and check each time to make sure both brakes work correctly before you get on the bike.

2. How brakes work

The braking action of a bicycle is a function of the friction between the braking surfaces.

To make sure that you have maximum friction available, keep your wheel rims and brake pads or the disk rotor and caliper clean and free of dirt, lubricants, waxes or polishes.

Brakes are designed to control your speed, not just to stop the bike. Maximum braking force for each wheel occurs at the point just before the wheel "locks up" (stops rotating) and starts to skid. Once the tire skids, you actually lose most of your stopping force and all directional control. You need to practice slowing and stopping smoothly without locking up a wheel. The technique is called progressive brake modulation. Instead of jerking the brake lever to the position where you think you'll generate appropriate braking force, squeeze the

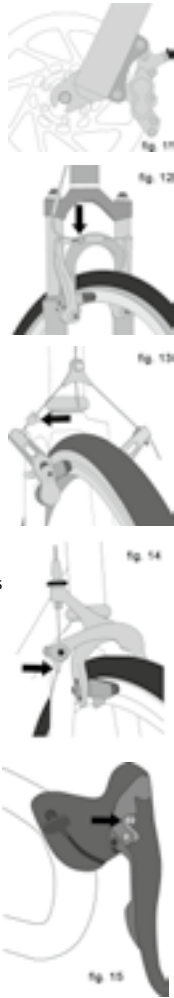

lever, progressively increasing the braking force. If you feel the wheel begin to lock up, release pressure just a little to keep the wheel rotating just short of lockup. It's important to develop a feel for the amount of brake lever pressure required for each wheel at different speeds and on different surfaces. To better understand this, experiment a little by walking your bike and applying different amounts of pressure to each brake lever, until the wheel locks.

When you apply one or both brakes, the bike begins to slow, but your body wants to continue at the speed at which it was going. This causes a transfer of weight to the front wheel (or, under heavy braking, around the front wheel hub, which could send you flying over the handlebars).

A wheel with more weight on it will accept greater brake pressure before lockup; a wheel with less weight will lock up with less brake pressure. So, as you apply brakes and your weight is transferred forward, you need to shift your body toward the rear of the bike, to transfer weight back on to the rear wheel; and at the same time, you need to both decrease rear braking and increase front braking force. This is even more important on descents, because descents shift weight forward.

Two keys to effective speed control and safe stopping are controlling wheel lockup and weight transfer. This weight transfer is even more pronounced if your bike has a front suspension fork. Front suspension "dips" under braking, increasing the weight transfer (see also Section 4.F). Practice braking and weight transfer techniques where there is no traffic or other hazards and distractions.

Everything changes when you ride on loose surfaces or in wet weather. It will take longer to stop on loose surfaces or in wet weather. Tire adhesion is reduced, so the wheels have less cornering and braking traction and can lock up with less brake force. Moisture or dirt on the brake pads reduces their ability to grip. The way to maintain control on loose or wet surfaces is to go more slowly.

D. Shifting gears

Your multi-speed bicycle will have a derailleur drivetrain (see 1. below), an internal gear hub drivetrain (see 2. below) or, in some special cases, a combination of the two.

1. How a derailleur drivetrain works

If your bicycle has a derailleur drivetrain, the gear-changing mechanism will have:

- a rear cassette or freewheel sprocket cluster
- a rear derailleur
- usually a front derailleur
- one or two shifters
- one, two or three front sprockets called chainrings
- a drive chain

a. Shifting Gears

There are several different types and styles of shifting controls: levers, twist grips, triggers, combination shift/brake controls and push-buttons. Ask your dealer to explain the type of shifting controls that are on your bike, and to show you how they work.

The vocabulary of shifting can be pretty confusing. A downshift is a shift to a "lower" or "slower" gear, one which is easier to pedal. An upshift is a shift to a "higher" or "faster", harder to pedal gear. What's confusing is that what's happening at the front derailleur is the opposite of what's happening at the rear derailleur (for details, read the instructions on Shifting the Rear Derailleur and Shifting the Front Derailleur below). For example, you can select a gear which will make pedaling easier on a hill (make a downshift) in one of two ways: shift the chain down the gear "steps" to a smaller gear at the front, or up the gear "steps" to a larger gear at the rear. So, at the rear gear cluster, what is called a downshift looks like an upshift. The way to keep things straight is to remember that shifting the chain in towards the centerline of the bike is for accelerating and climbing and is called a downshift. Moving the chain out or away from the centerline of the bike is for speed and is called an upshift.

Whether upshifting or downshifting, the bicycle derailleur system design requires that the drive chain is moving forward and be under at least some tension. A derailleur will shift only if you are pedaling forward.

CAUTION: Never move the shifter while pedaling backward, nor pedal backwards immediately after having moved the shifter. This could jam the chain and cause serious damage to the bicycle.

b. Shifting the Rear Derailleur

The rear derailleur is controlled by the right shifter. The function of the rear derailleur is to move the drive chain from one gear sprocket to another. The smaller sprockets on the gear cluster produce higher gear ratios. Pedaling in the higher gears requires greater pedaling effort, but takes you a greater distance with each revolution of the pedal cranks. The larger sprockets produce lower gear ratios. Using them requires less pedaling effort, but takes you a shorter distance with each pedal crank revolution. Moving the chain from a smaller sprocket of the gear cluster to a larger sprocket results in a downshift. Moving the chain from a larger sprocket to a smaller sprocket results in an upshift. In order for the derailleur to move the chain from one sprocket to another, the rider must be pedaling forward.

c. Shifting the Front Derailleur:

The front derailleur, which is controlled by the left shifter, shifts the chain between the larger and smaller chainrings. Shifting the chain onto a smaller chainring makes pedaling easier (a downshift). Shifting to a larger chainring makes pedaling harder (an upshift).

d. Which gear should I be in?

The combination of largest rear and smallest front gears (fig. 16) is for the steepest hills. The smallest rear and largest front combination is for the greatest speed. It is not necessary to shift gears in sequence. Instead, find the "starting gear" which is right for your level of ability — a gear which is hard enough for quick acceleration but easy enough to let you start from a stop without wobbling — and experiment with upshifting and downshifting to get a feel for the different gear combinations. At first, practice shifting where there are no obstacles, hazards or other traffic, until you've built up your confidence. Learn not to use either the "smallest to smallest" or "largest to largest" gear combinations because they may cause unacceptable stress on the drive train. Learn to anticipate the need to shift, and shift to a lower gear *before* the hill gets too steep. If you have difficulties with shifting, the problem could be mechanical adjustment. See your dealer for help.

WARNING: Never shift a derailleur onto the largest or the smallest sprocket if the derailleur is not shifting smoothly. The derailleur may be out of adjustment and the chain could jam, causing you to lose control and fall.

e. What if it won't shift gears?

If moving the shift control one click repeatedly fails to result in a smooth shift to the next gear chances are that the mechanism is out of adjustment. Take the bike to your dealer to have it adjusted.

2. How an internal gear hub drivetrain works

If your bicycle has an internal gear hub drivetrain, the gear changing mechanism will consist of:

- a 3, 5, 7, 8, 11, 12, 14, 18 speed or possibly an infinitely variable internal gear hub
- one, or sometimes two shifters
- one or two control cables
- one front sprocket called a chainring
- a drive chain

a. Shifting internal gear hub gears

Shifting with an internal gear hub drivetrain is simply a



matter of moving the shifter to the indicated position for the desired gear ratio. After you have moved the shifter to the gear position of your choice, ease the pressure on the pedals for an instant to allow the hub to complete the shift.

b. Which gear should I be in?

The numerically lowest gear (1) is for the steepest hills. The numerically largest gear is for the greatest speed.

Shifting from an easier, “slower” gear (like 1) to a harder, “faster” gear (like 2 or 3) is called an upshift. Shifting from a harder, “faster” gear to an easier, “slower” gear is called a downshift. It is not necessary to shift gears in sequence. Instead, find the “starting gear” for the conditions — a gear which is hard enough for quick acceleration but easy enough to let you start from a stop without wobbling — and experiment with upshifting and downshifting to get a feel for the different gears. At first, practice shifting where there are no obstacles, hazards or other traffic, until you’ve built up your confidence. Learn to anticipate the need to shift, and shift to a lower gear *before* the hill gets too steep. If you have difficulties with shifting, the problem could be mechanical adjustment. See your dealer for help.

c. What if it won’t shift gears?

If moving the shift control one click repeatedly fails to result in a smooth shift to the next gear chances are that the mechanism is out of adjustment. Take the bike to your dealer to have it adjusted.

E. Pedals

1. Toe Overlap is when your toe can touch the front wheel when you turn the handlebars to steer while a pedal is in the forwardmost position. This is common on small-framed bicycles, and is avoided by keeping the inside pedal up and the outside pedal down when making sharp turns. On any bicycle, this technique will also prevent the inside pedal from striking the ground in a turn.

NOTE: Changing tire size or pedal crank arm length affects toe overlap.

WARNING: Toe Overlap could cause you to lose control and fall. Ask your dealer to help you determine if the combination of frame size, crank arm length, pedal design and shoes you will use results in pedal overlap. Whether you have overlap or not, you must keep the inside pedal up and the outside pedal down when making sharp turns.

2. Some bicycles come equipped with pedals that have sharp and potentially dangerous surfaces. These surfaces are designed to add safety by increasing grip between the

rider’s shoe and the pedal. If your bicycle has this type of high-performance pedal, you must take extra care to avoid serious injury from the pedals’ sharp surfaces. Based on your riding style or skill level, you may prefer a less aggressive pedal design, or chose to ride with shin pads. Your dealer can show you a number of options and make suitable recommendations.

3. Toeclips and straps are a means to keep feet correctly positioned and engaged with the pedals. The toeclip positions the ball of the foot over the pedal spindle, which gives maximum pedaling power. The toe strap, when tightened, keeps the foot engaged throughout the rotation cycle of the pedal. While toeclips and straps give some benefit with any kind of shoe, they work most effectively with cycling shoes designed for use with toeclips. Your dealer can explain how toeclips and straps work. Shoes with deep treaded soles or welts which might make it more difficult for you to insert or remove your foot should not be used with toeclips and straps.

WARNING: Getting into and out of pedals with toeclips and straps requires skill which can only be acquired with practice. Until it becomes a reflex action, the technique requires concentration which can distract your attention and cause you to lose control and fall. Practice the use of toeclips and straps where there are no obstacles, hazards or traffic. Keep the straps loose, and don’t tighten them until your technique and confidence in getting in and out of the pedals warrants it. Never ride in traffic with your toe straps tight.

4. Clipless pedals (sometimes called “step-in pedals”) are another means to keep feet securely in the correct position for maximum pedaling efficiency. They have a plate, called a “cleat,” on the sole of the shoe, which clicks into a mating spring-loaded fixture on the pedal. They only engage or disengage with a very specific motion which must be practiced until it becomes instinctive. Clipless pedals require shoes and cleats which are compatible with the make and model pedal being used.

Many clipless pedals are designed to allow the rider to adjust the amount of force needed to engage or disengage the foot. Follow the pedal manufacturer’s instructions, or ask your dealer to show you how to make this adjustment. Use the easiest setting until engaging and disengaging becomes a reflex action, but always make sure that there is sufficient tension to prevent unintended release of your foot from the pedal.

WARNING: Clipless pedals are intended for use with shoes specifically made to fit them and are designed to firmly keep the foot engaged with the pedal. Do not use shoes which do not engage the pedals correctly.

Practice is required to learn to engage and disengage the foot safely. Until engaging and disengaging the foot becomes a reflex action, the technique requires concentration which can distract your attention and cause you to lose control and fall. Practice engaging and disengaging clipless pedals in a place where there are no obstacles, hazards or traffic; and be sure to follow the pedal manufacturer’s setup and service instructions. If you do not have the manufacturer’s instructions, see your dealer or contact the manufacturer.

F. Bicycle Suspension

Many bicycles are equipped with suspension systems. There are many different types of suspension systems — too many to deal with individually in this manual. If your bicycle has a suspension system of any kind, be sure to read, understand and follow the suspension manufacturer’s setup and service instructions. If you do not have the manufacturer’s instructions, see your dealer or contact the manufacturer.

WARNING: Failure to maintain, check and properly adjust the suspension system may result in suspension malfunction, which may cause you to lose control and fall.

If your bike has suspension, the increased speed you may develop also increases your risk of injury. For example, when braking, the front of a suspended bike dips. You could lose control and fall if you do not have experience with this system. Learn to handle your suspension system safely. See also Section 4.C.

WARNING: Changing suspension adjustment can change the handling and braking characteristics of your bicycle. Never change suspension adjustment unless you are thoroughly familiar with the suspension system manufacturer’s instructions and recommendations, and always check for changes in the handling and braking characteristics of the bicycle after a suspension adjustment by taking a careful test ride in a hazard-free area.

Suspension can increase control and comfort by allowing the wheels to better follow the terrain. This enhanced capability may allow you to ride faster; but you must not confuse the enhanced capabilities of the bicycle with your own capabilities as a rider. Increasing your skill will take time and practice. Proceed carefully until you have learned to handle the full capabilities of your bike.

WARNING: Not all bicycles can be safely retrofitted with some types of suspension systems. Before retrofitting a bicycle with any suspension, check with the bicycle’s manufacturer to make sure that what you want to do is compatible with the bicycle’s design. Failing to do so can result in catastrophic frame failure.

G. Tires and Tubes

WARNING: Some bicycles intended for competition are fitted with tires which are glued on to specially made rims. These are called “sew-up” or “tubular” tires. Properly mounting these tires requires specialized knowledge and skills. Ask your dealer to teach you how to mount tubulars before you attempt it on your own. An incorrectly installed tubular tire can come off the rim, causing you to lose control and fall.

1. Tires

Bicycle tires are available in many designs and specifications, ranging from general-purpose designs to tires designed to perform best under very specific weather or terrain conditions. If, once you’ve gained experience with your new bike, you feel that a different tire might better suit your riding needs, your dealer can help you select the most appropriate design.

The size, pressure rating, and on some high-performance tires the specific recommended use, are marked on the sidewall of the tire (see fig. 17). The part of this information which is most important to you is Tire Pressure. But some wheel rim manufacturers also specify maximum tire pressure with a label on the rim.

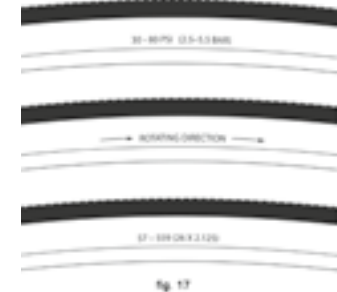

WARNING: Never inflate a tire beyond the maximum pressure marked on the tire’s sidewall or the wheel rim. If the maximum pressure rating for the wheel rim is lower than the maximum pressure shown on the tire, always use the lower rating. Exceeding the recommended maximum pressure may blow the tire off the rim or damage the wheel rim, which could cause damage to the bike and injury to the rider and bystanders.

The best and safest way to inflate a bicycle tire to the correct pressure is with a bicycle pump which has a built-in pressure gauge.

WARNING: There is a safety risk in using gas station air hoses or other air compressors. They are not made for bicycle tires. They move a large volume of air very rapidly, and will raise the pressure in your tire very rapidly, which could cause the tube to explode.

Tire pressure is given either as maximum pressure or as a pressure range. How a tire performs under different terrain or weather conditions depends largely on tire pressure. Inflating the tire to near its maximum recommended pressure gives the lowest rolling resistance; but also produces the harshest ride. High pressures work best on smooth, dry pavement.

Very low pressures, at the bottom of the recommended pressure range, give the best performance on smooth, slick terrain such as hard-packed clay, and on deep, loose surfaces such as deep, dry sand.

Tire pressure that is too low for your weight and the riding conditions can cause a puncture of the tube by allowing the tire to deform sufficiently to pinch the inner tube between the rim and the riding surface. It can also lead to a tire that slips of the rim in sharp turns or during aggressive moves. Both can lead to falls and injuries.

CAUTION: Pencil type automotive tire gauges can be inaccurate and should not be relied upon for consistent, accurate pressure readings. Instead, use a high quality dial gauge.

Ask your dealer to recommend the best tire pressure for the kind of riding you will most often do, and have the dealer inflate your tires to that pressure. Then, check inflation as described in Section 1.C so you'll know how correctly inflated tires should look and feel when you don't have access to a gauge. Some tires may need to be brought up to pressure every week or two, so it is important to check your tire pressures before every ride.

Some special high-performance tires have unidirectional treads: their tread pattern is designed to work better in one direction than in the other. The sidewall marking of a unidirectional tire will have an arrow showing the correct rotation direction. If your bike has unidirectional tires, be sure that they are mounted to rotate in the correct direction.

2. Tire Valves

There are primarily two kinds of bicycle tire valves: The Schraeder Valve and the Presta Valve. The bicycle pump you use must have the fitting appropriate to the valve stems on your bicycle.

The Schraeder valve (fig. 18a) is like the valve

on a car tire. To inflate a Schraeder valve tire, remove the valve cap and clamp the pump fitting onto the end of the valve stem. To let air out of a Schraeder valve, depress the pin in the end of the valve stem with the end of a key or other appropriate object.

The Presta valve (fig. 18b) has a narrower diameter and is only found on bicycle tires. To inflate a Presta valve tire using a Presta headed bicycle pump, remove the valve cap; unscrew (counterclockwise) the valve stem lock nut; and push down on the valve stem to free it up. Then push the pump head on to the valve head, and inflate. To inflate a Presta valve with a Schraeder pump fitting, you'll need a Presta adapter (available at your bike shop) which screws on to the valve stem once you've freed up the valve. The adapter fits into the Schraeder pump fitting. Close the valve after inflation. To let air out of a Presta valve, open up the valve stem lock nut and depress the valve stem.



WARNING: We highly recommend that you carry a spare inner tube when you ride your bike, unless the bike is fitted with tubeless tires. Patching a tube is an emergency repair. If you do not apply the patch correctly or apply several patches, the tube can fail, resulting in possible tube failure, which could cause you to lose control and fall. Replace a patched tube as soon as possible.

5. Service

WARNING: Technological advances have made bicycles and bicycle components more complex, and the pace of innovation is increasing. It is impossible for this manual to provide all the information required to properly repair and/or maintain your bicycle. In order to help minimize the chances of an accident and possible injury, it is critical that you have any repair or maintenance which is not specifically described in this manual performed by your dealer. Equally important is that your individual maintenance requirements will be determined by everything from your riding style to geographic location. Consult your dealer for help in determining your maintenance requirements.

WARNING: Many bicycle service and repair tasks require special knowledge and tools. Do not begin any adjustments or service on your bicycle until you have learned from your dealer how to properly complete them. Improper adjustment or service may result in damage to the bicycle or in an accident which can cause serious injury or death.

If you want to learn to do major service and repair work on your bike:

1. Ask your dealer for copies of the manufacturer's installation and service instructions for the components on your bike, or contact the component manufacturer.
2. Ask your dealer to recommend a book on bicycle repair.
3. Ask your dealer about the availability of bicycle repair courses in your area.

We recommend that you ask your dealer to check the quality of your work the first time you work on something and before you ride the bike, just to make sure that you did everything correctly. Since that will require the time of a mechanic, there may be a modest charge for this service.

We also recommend that you ask your dealer for guidance on what spare parts, such as tires, inner tubes, light bulbs, batteries, Pach Kit, lubricants etc. it would be appropriate for you to have once you have learned how to replace such parts when they require replacement.

A. Service Intervals

Some service and maintenance can and should be performed by the owner, and require no special tools or knowledge beyond what is presented in this manual.

The following are examples of the type of service you should perform yourself. All other service, maintenance and repair should be performed in a properly equipped facility by a qualified bicycle mechanic using the correct tools and procedures specified by the manufacturer.

1. Break-in Period: Your bike will last longer and work better if you break it in before riding it hard. Control cables and wheel spokes may stretch or "seat" when a new bike is first used and may require readjustment by your dealer. Your Mechanical Safety Check (Section 1.C) will help you identify some things that need readjustment. But even if everything seems fine to you, it's best to take your bike back to the dealer for a checkup. Dealers typically suggest you bring the bike in for a 30 day checkup. Another way to judge when it's time for the first checkup is to bring the bike in after three to five hours of hard off-road use, or about 10 to 15 hours of on-road or more casual off-road use. But if you think something is wrong with the bike, take it to your dealer before riding it again.
2. Before every ride: Mechanical Safety Check (Section 1.C)
3. After every long or hard ride; if the bike has been exposed to water or grit; or at least every 100 miles: Clean the bike and lightly lubricate the chain's rollers with a good quality bicycle chain lubricant. Wipe off excess lubricant with a lint-free cloth. Lubrication is a function of climate. Talk to your dealer about the best lubricants and the recommended lubrication frequency for your area.
4. After every long or hard ride or after every 10 to 20

hours of riding:

- Squeeze the front brake and rock the bike forward and back. Everything feel solid? If you feel a clunk with each forward or backward movement of the bike, you probably have a loose headset. Have your dealer check it.
 - Lift the front wheel off the ground and swing it from side to side. Feel smooth? If you feel any binding or roughness in the steering, you may have a tight headset. Have your dealer check it.
 - Grab one pedal and rock it toward and away from the centerline of the bike; then do the same with the other pedal. Anything feel loose? If so, have your dealer check it.
 - Take a look at the brake pads. Starting to look worn or not hitting the wheel rim squarely? Time to have the dealer adjust or replace them.
 - Carefully check the control cables and cable housings. Any rust? Kinks? Fraying? If so, have your dealer replace them.
 - Squeeze each adjoining pair of spokes on either side of each wheel between your thumb and index finger. Do they all feel about the same? If any feel loose, have your dealer check the wheel for tension and trueness.
 - Check the tires for excess wear, cuts or bruises. Have your dealer replace them if necessary.
 - Check the wheel rims for excess wear, dings, dents and scratches. Consult your dealer if you see any rim damage.
 - Check to make sure that all parts and accessories are still secure, and tighten any which are not.
 - Check the frame, particularly in the area around all tube joints; the handlebars; the stem; and the seatpost for any deep scratches, cracks or discoloration. These are signs of stress-caused fatigue and indicate that a part is at the end of its useful life and needs to be replaced. See also Appendix B.
- WARNING:** Like any mechanical device, a bicycle and its components are subject to wear and stress. Different materials and mechanisms wear or fatigue from stress at different rates and have different life cycles. If a component's life cycle is exceeded, the component can suddenly and catastrophically fail, causing serious injury or death to the rider. Scratches, cracks, fraying and discoloration are signs of stress-caused fatigue and indicate that a part is at the end of its useful life and needs to be replaced. While the materials and workmanship of your bicycle or of individual components may be covered by a warranty for a specified period of time by the manufacturer, this is no guarantee that the product will last the term of the warranty. Product life is often related to the kind of riding you do and to the treatment to which you submit the bicycle. The bicycle's warranty is not meant to suggest that the bicycle cannot be broken or will last forever. It only means that the bicycle is covered subject to the terms of the warranty. Please be sure to



read Appendix A, Intended Use of your bicycle and Appendix B, The lifespan of your bike and its components, starting on page 28.

5. As required: If either brake lever fails the Mechanical Safety Check (Section 1.C), don't ride the bike. Have your dealer check the brakes.

If the chain won't shift smoothly and quietly from gear to gear, the derailleur is out of adjustment. See your dealer.

6. Every 25 (hard off-road) to 50 (on-road) hours of riding: Take your bike to your dealer for a complete checkup.

B. If your bicycle sustains an impact:

First, check yourself for injuries, and take care of them as best you can. Seek medical help if necessary.

Next, check your bike for damage.

After any crash, take your bike to your dealer for a thorough check. Carbon composite components, including frames, wheels, handlebars, stems, cranksets, brakes, etc. which have sustained an impact *must not* be ridden until they have been disassembled and thoroughly inspected by a qualified mechanic.

See also Appendix B, Lifespan of your bike and its components.

WARNING: A crash or other impact can put extraordinary stress on bicycle components, causing them to fatigue prematurely. Components suffering from stress fatigue can fail suddenly and catastrophically, causing loss of control, serious injury or death.

Appendix A Intended use of your bicycle

WARNING: Understand your bike and its intended use. Choosing the wrong bicycle for your purpose can be hazardous. Using your bike the wrong way is dangerous.

No one type of bicycle is suited for all purposes. Your retailer can help you pick the "right tool for the job" and help you understand its limitations. There are many types of bicycles and many variations within each type. There are many types of mountain, road, racing, hybrid, touring, cyclocross and tandem bicycles.

There are also bicycles that mix features. For example, there are road/racing bikes with triple cranks. These bikes have the low gearing of a touring bike, the quick handling of a racing bike, but are not well suited for carrying heavy loads on a tour. For that purpose you want a touring bike.

Within each of type of bicycle, one can optimize for certain purposes. Visit your bicycle shop and find someone with expertise in the area that interests you. Do your own homework. Seemingly small changes such as the choice of tires can improve or diminish the performance of a bicycle for a certain purpose.

Industry usage conditions are generalized and evolving. Consult your dealer about how you intend to use your bike. "If your bike is equipped like legally required it might be used like explained in the following:"

General Purpose Riding

Bikes designed for riding on a paved surface or smooth gravel roads and improved trails with moderate grades where the tires do not lose ground contact.

INTENDED For paved roads, gravel or dirt roads that are in good condition, and bike paths.

NOT INTENDED For off-road or mountain bike use, or for any kind of jumping. Some of these bikes have suspension features, but these features are designed to add comfort, not off-road capability. Some come with relatively wide tires that are well suited to gravel or dirt paths. Some come with relatively narrow tires that are best suited to faster riding on pavement. If you ride on gravel or dirt paths, carry heavier loads or want more tire durability talk to your dealer about wider tires.

MAXIMUM WEIGHT LIMIT

RIDER	LUGGAGE	TOTAL*
lbs / kg	lbs / kg	lbs / kg
220 / 100	59 / 27	286 / 130**

*Maximum Total weight is the weight of the rider + weight of the luggage + weight of the bike itself

**The maximum total weight is the standard and guiding limit, unless otherwise indicated on the bicycle

Appendix B The lifespan of your bike and its components

1. Nothing Lasts Forever, Including Your Bike.

When the useful life of your bike or its components is over, continued use is hazardous.

Every bicycle and its component parts have a finite, limited useful life. The length of that life will vary with the construction and materials used in the frame and components; the maintenance and care the frame and components receive over their life; and the type and amount of use to which the frame and components are subjected. Use in competitive events, trick riding, ramp riding, jumping, aggressive riding, riding on severe terrain, riding in severe climates, riding with heavy loads, commercial activities and other types of non-standard use can dramatically shorten the life of the frame and components. Any one or a combination of these conditions may result in an unpredictable failure.

All aspects of use being identical, lightweight bicycles and their components will usually have a shorter life than heavier bicycles and their components. In selecting a lightweight bicycle or components you are making a tradeoff, favoring the higher performance that comes with lighter weight over longevity. So, if you choose lightweight, high performance equipment, be sure to have it inspected frequently.

You should have your bicycle and its components checked periodically by your dealer for indicators of stress and/or potential failure, including cracks, deformation, corrosion, paint peeling, dents, and any other indicators of potential problems, inappropriate use or abuse. These are important safety checks and very important to help prevent accidents, bodily injury to the rider and shortened product life.

2. Perspective

Today's high-performance bicycles require frequent and careful inspection and service. In this Appendix we try to explain some underlying material science basics and how they relate to your bicycle. We discuss some of the trade-offs made in designing your bicycle and what you can expect from your bicycle; and we provide important, basic guidelines on how to maintain and inspect it. We cannot teach you everything you need to know to properly inspect and service your bicycle; and that is why we repeatedly urge you to take your bicycle to your dealer for professional care and attention.

WARNING: Frequent inspection of your bike is important to your safety. Follow the Mechanical Safety Check in Section 1.C of this Manual before every ride.

Periodic, more detailed inspection of your bicycle is important. How often this more detailed inspection is needed depends upon you.

You, the rider/owner, have control and knowledge of how often you use your bike, how hard you use it and where you use it. Because your dealer cannot track your use, you must take responsibility for periodically bringing your bike to your dealer for inspection and service. Your dealer will help you decide what frequency of inspection and service is appropriate for how and where you use your bike.

For your safety, understanding and communication with your dealer, we urge you to read this Appendix in its entirety. The materials used to make your bike determine how and how frequently to inspect.

Ignoring this WARNING can lead to frame, fork or other component failure, which can result in serious injury or death.

A. Understanding metals

Steel is the traditional material for building bicycle frames. It has good characteristics, but in high performance bicycles, steel has been largely replaced by aluminum, carbon fibre and some titanium. The main factor driving this change is interest by cycling enthusiasts in lighter bicycles.

Properties of Metals

Please understand that there is no simple statement that can be made that characterizes the use of different metals for bicycles. What is true is how the metal chosen is applied is much more important than the material alone. One must look at the way the bike is designed, tested, manufactured, supported along with the characteristics of the metal rather than seeking a simplistic answer.

Metals vary widely in their resistance to corrosion. Steel must be protected or rust will attack it. Aluminum and Titanium quickly develop an oxide film that protects the metal from further corrosion. Both are therefore quite resistant to corrosion. Aluminum is not perfectly corrosion resistant, and particular care must be used where it contacts other metals and galvanic corrosion can occur.

Metals are comparatively ductile. Ductile means bending, buckling and stretching before breaking. Generally speaking, of the common bicycle frame building materials steel is the most ductile, titanium less ductile, followed by aluminum.

Metals vary in density. Density is weight per unit of material. Steel weighs 7.8 grams/cm³ (grams per cubic centimeter), titanium 4.5 grams/cm³, aluminum 2.75 grams/cm³. Contrast these numbers with carbon fiber composite at 1.45 grams/cm³.

Metals are subject to fatigue. With enough cycles of use, at high enough loads, metals will eventually develop



cracks that lead to failure. It is very important that you read The basics of metal fatigue below.

Let's say you hit a curb, ditch, rock, car, another cyclist or other object. At any speed above a fast walk, your body will continue to move forward, momentum carrying you over the front of the bike. You cannot and will not stay on the bike, and what happens to the frame, fork and other components is irrelevant to what happens to your body.

What should you expect from your metal frame? It depends on many complex factors, which is why we tell you that crashworthiness cannot be a design criteria. With that important note, we can tell you that if the impact is hard enough the fork or frame may be bent or buckled.

On a steel bike, the steel fork may be severely bent and the frame undamaged. Aluminum is less ductile than steel, but you can expect the fork and frame to be bent or buckled. Hit harder and the top tube may be broken in tension and the down tube buckled. Hit harder and the top tube may be broken, the down tube buckled and broken, leaving the head tube and fork separated from the main triangle.

When a metal bike crashes, you will usually see some evidence of this ductility in bent, buckled or folded metal.

It is now common for the main frame to be made of metal and the fork of carbon fiber. See Section B, *Understanding composites* below. The relative ductility of metals and the lack of ductility of carbon fiber means that in a crash scenario you can expect some bending or buckling in the metal but none in the carbon. Below some load the carbon fork may be intact even though the frame is damaged. Above some load the carbon fork will be completely broken.

The basics of metal fatigue

What to look for

<p>• ONCE A CRACKS STARTS IT CAN GROW AND GROW FAST. Think about the crack as forming a pathway to failure. This means that any crack is potentially dangerous and will only become more dangerous.</p>	<p>SIMPLE RULE 1 : If you find crack, replace the part.</p>
<p>• CORROSION SPEEDS DAMAGE. Cracks grow more quickly when they are in a corrosive environment. Think about the corrosive solution as further weakening and extending the crack.</p>	<p>SIMPLE RULE 2 : Clean your bike, lubricate your bike, protect your bike from salt, remove any salt as soon as you can. Repair cracks in the paint or powder coating.</p>
<p>• STAINS AND DISCOLORATION CAN OCCUR NEAR A CRACK. Such staining may be a warning sign that a crack exists.</p>	<p>SIMPLE RULE 3 : Inspect and investigate any staining to see if it is associated with a crack.</p>
<p>• SIGNIFICANT SCRATCHES, GOUGES, DENTS OR SCORING CREATE STARTING POINTS FOR CRACKS. Think about the cut surface as a focal point for stress (in fact engineers call such areas "stress risers," areas where the stress is increased). Perhaps you have seen glass cut? Recall how the glass was scored and then broke on the scored line.</p>	<p>SIMPLE RULE 4 : Do not scratch, gouge or score any surface. If you do, pay frequent attention to this area or replace the part.</p>
<p>• SOME CRACKS (particularly larger ones) MAY MAKE CREAKING NOISE AS YOU RIDE. Think about such a noise as a serious warning signal. Note that a well-maintained bicycle will be very quiet and free of creaks and squeaks.</p>	<p>SIMPLE RULE 5 : Investigate and find the source of any noise. It may not be a crack, but whatever is causing the noise should be fixed promptly.</p>

Common sense tells us that nothing that is used lasts forever. The more you use something, and the harder you use it, and the worse the conditions you use it in, the shorter its life.

Fatigue is the term used to describe accumulated damage to a part caused by repeated loading. To cause fatigue damage, the load the part receives must be great enough. A crude, often-used example is bending a paper clip back and forth (repeated loading) until it breaks. This simple definition will help you understand that fatigue has nothing to do with time or age. A bicycle in a garage does not fatigue. Fatigue happens only through use.

So what kind of "damage" are we talking about? On a microscopic level, a crack forms in a highly stressed area. As the load is repeatedly applied, the crack grows. At some point the crack becomes visible to the naked eye. Eventually it becomes so large that the part is too weak to carry the load that it could carry without the crack. At that point there can be a complete and immediate failure of the part.

One can design a part that is so strong that fatigue life is nearly infinite. This requires a lot of material and a lot of weight. Any structure that must be light and strong will have a finite fatigue life. Aircraft, race cars, motorcycles all have parts with finite fatigue lives. If you wanted a bicycle with an infinite fatigue life, it would weigh far more than any bicycle sold today. So we all make a tradeoff: the wonderful, lightweight performance we want requires that we inspect the structure.

In most cases a fatigue crack is not a defect. It is a sign that the part has been worn out, a sign the part has reached the end of its useful life. When your car tires wear down to the point that the tread bars are contacting the road, those tires are not defective. Those tires are worn out and the tread bar says "time for replacement." When a metal part shows a fatigue crack, it is worn out. The crack says "time for replacement."

Fatigue Is Not A Perfectly Predictable Science

Fatigue is not a perfectly predictable science, but here are some general factors to help you and your dealer determine how often your bicycle should be inspected. The more you fit the "shorten product life" profile, the more frequent your need to inspect. The more you fit the "lengthen product life" profile, the less frequent your need to inspect.

Factors that shorten product life:

- ▶ **Hard, harsh riding style**
- ▶ **"Hits", crashes, jumps, other "shots" to the bike**
- ▶ **High mileage**
- ▶ **Higher body weight**
- ▶ **Stronger, more fit, more aggressive rider**
- ▶ **Corrosive environment (wet, salt air, winter road salt, accumulated sweat)**
- ▶ **Presence of abrasive mud, dirt, sand, soil in riding environment**

Factors that lengthen product life:

- ▶ **Smooth, fluid riding style**
- ▶ **No "hits", crashes, jumps, other "shots" to the bike**
- ▶ **Low mileage**
- ▶ **Lower body weight**
- ▶ **Less aggressive rider**
- ▶ **Non-corrosive environment (dry, salt-free air)**
- ▶ **Clean riding environment**

 **WARNING: Do not ride a bicycle or component with any crack, bulge or dent, even a small one. Riding a cracked frame, fork or component could lead to complete failure, with risk of serious injury or death.**

B. Understanding composites

All riders must understand a fundamental reality of composites. Composite materials constructed of carbon fibers are strong and light, but when crashed or overloaded, carbon fibers do not bend, they break.

What Are Composites?

The term "composites" refers to the fact that a part or parts are made up of different components or materials. You've heard the term "carbon fiber bike." This really means "composite bike."

Carbon fiber composites are typically a strong, light fiber in a matrix of plastic, molded to form a shape. Carbon composites are light relative to metals. Steel weighs 7.8 grams/cm³ (grams per cubic centimeter), titanium 4.5 grams/cm³, aluminum 2.75 grams/cm³. Contrast these numbers with carbon fiber composite at 1.45 grams/cm³.

The composites with the best strength-to-weight ratios are made of carbon fiber in a matrix of epoxy plastic. The epoxy matrix bonds the carbon fibers together, transfers load to other fibers, and provides a smooth outer surface. The carbon fibers are the "skeleton" that carries the load.

Why Are Composites Used?

Unlike metals, which have uniform properties in all directions (engineers call this isotropic), carbon fibers can be placed in specific orientations to optimize the structure for particular loads. The choice of where to place the carbon fibers gives engineers a powerful tool to create strong, light bicycles. Engineers may also orient fibers to suit other goals such as comfort and vibration damping.

Carbon fiber composites are very corrosion resistant, much more so than most metals.

Think about carbon fiber or fiberglass boats.

Carbon fiber materials have a very high strength-to-weight ratio.

What Are The Limits Of Composites?

Well designed "composite" or carbon fiber bicycles and components have long fatigue lives, usually better than their metal equivalents.

While fatigue life is an advantage of carbon fiber, you must still regularly inspect your carbon fiber frame, fork, or components.

Carbon fiber composites are not ductile. Once a carbon structure is overloaded, it will not bend; it will break. At and near the break, there will be rough, sharp edges and maybe delamination of carbon fiber or carbon fiber fabric layers. There will be no bending, buckling, or stretching.

If You Hit Something Or Have A Crash, What Can You Expect From Your Carbon Fiber Bike?

 **WARNING:** Defects and cracks in composites might appear without being visible! If you have had a crash, ear unusual noises or feel a difference while riding, let your dealer check the bike or the part. Don't continue the ride before having the bike or part being checked!

Let's say you hit a curb, ditch, rock, car, other cyclist or other object. At any speed above a fast walk, your body will continue to move forward, the momentum carrying you over the front of the bike. You cannot and will not stay on the bike and what happens to the frame, fork and other



components is irrelevant to what happens to your body.

What should you expect from your carbon frame? It depends on many complex factors. But we can tell you that if the impact is hard enough, the fork or frame may be completely broken. Note the significant difference in behavior between carbon and metal. See Section 2. A, *Understanding metals* in this Appendix. Even if the carbon frame was twice as strong as a metal frame, once the carbon frame is overloaded it will not bend, it will break completely.

WARNING: Be aware that high temperature in a confined environment can affect the integrity of composite materials, resulting in component failure which could cause you to lose control and fall. This begins at temperatures like in a car, standing in bright sunlight for a while!

Inspection of Composite Frame, Fork, and Components Cracks:

Inspect for cracks, broken, or splintered areas. Any crack is serious. Do not ride any bicycle or component that has a crack of any size. **Delamination:**

WARNING: Delaminations in composites might appear without being visible! If you have had a crash, ear unusual noises or feel a difference while riding, let your dealer check the bike or the part. Don't continue the ride before having the bike or part being checked!

Delamination is serious damage. Composites are made from layers of fabric. Delamination means that the layers of fabric are no longer bonded together. Do not ride any bicycle or component that has any delamination. These are some delamination clues:

- A cloudy or white area. This kind of area looks different from the ordinary undamaged areas. Undamaged areas will look glassy, shiny, or "deep," as if one was looking into a clear liquid. Delaminated areas will look opaque and cloudy.
- Bulging or deformed shape. If delamination occurs, the surface shape may change. The surface may have a bump, a bulge, soft spot, or not be smooth and fair.
- A difference in sound when tapping the surface. If you gently tap the surface of an undamaged composite you will hear a consistent sound, usually a hard, sharp sound. If you then tap a delaminated area, you will hear a different sound, usually duller, less sharp.

Unusual Noises:

Either a crack or delamination can cause creaking noises while riding. Think about such a noise as a serious warning signal. A well maintained bicycle will be very

quiet and free of creaks and squeaks. Investigate and find the source of any noise. It may not be a crack or delamination, but whatever is causing the noise must be fixed or replaced before riding.

WARNING: Do not ride a bicycle or component with any delamination or crack. Riding a delaminated or cracked frame, fork or other component could lead to complete failure, with risk of serious injury or death.

C. Understanding components

It is often necessary to remove and disassemble components in order to properly and carefully inspect them. This is a job for a professional bicycle mechanic with the special tools, skills and experience to inspect and service today's high-tech high-performance bicycles and their components.

Aftermarket "Super Light" components

Think carefully about your rider profile as outlined above. The more you fit the "shorten product life" profile, the more you must question the use of super light components. The more you fit the "lengthen product life" profile, the more likely it is that lighter components may be suitable for you. Discuss your needs and your profile very honestly with your dealer. Take these choices seriously and understand that you are responsible for the changes.

A useful slogan to discuss with your dealer if you contemplate changing components is "Strong, Light, Cheap –pick two."

Original Equipment components

Bicycle and component manufacturers test the fatigue life of the components that are original equipment on your bike. This means that they have met test criteria and have reasonable fatigue life. It does not mean that the original components will last forever. They won't.

Appendix C Coaster Brake

1. How the coaster brake works

The coaster brake is a sealed mechanism which is a part of the bicycle's rear wheel hub. The brake is activated by reversing the rotation of the pedal cranks (see fig. 5). Start with the pedal cranks in a nearly horizontal position, with the front pedal in about the 4 o'clock position, and apply downward foot pressure on the pedal that is to the rear. About 1/8 turn rotation will activate the brake. The more downward pressure you apply, the more braking force, up to the point where the rear wheel stops rotating and begins to skid.

WARNING: Before riding, make sure that the brake is working properly. If it is not working properly, have the bicycle checked by your dealer before you ride it.

WARNING: If your bike has only a coaster brake, ride conservatively. A single rear brake does not have the stopping power of front-and-rear brake systems.

2. Adjusting your coaster brake

Coaster brake service and adjustment requires special tools and special knowledge. Do not attempt to disassemble or service your coaster brake. Take the bicycle to your dealer for coaster brake service.



fig. 5

Appendix D Fastener Torque Specifications

Correct tightening torque of threaded fasteners is very important to your safety. Always tighten fasteners to the correct torque. In case of a conflict between the instructions in this manual and information provided by a component manufacturer, consult with your dealer or the manufacturer's customer service representative for clarification. Bolts that are too tight can stretch and deform. Bolts that are too loose can move and fatigue. Either mistake can lead to a sudden failure of the bolt.

Always use a correctly calibrated torque wrench to tighten critical fasteners on your bike. Carefully follow the torque wrench manufacturer's instructions on the correct way to set and use the torque wrench for accurate results.

FASTENER RECOMMENDED TORQUE

WHEELS
PEDALS
SEAT POST CLAMP
SADDLE CLAMP
STEERER CLAMP
HANDLEBAR CLAMP
CONTROL LEVER CLAMPS

6 Drive Unit

6.1 Drive Unit Performance Line

BDU3360



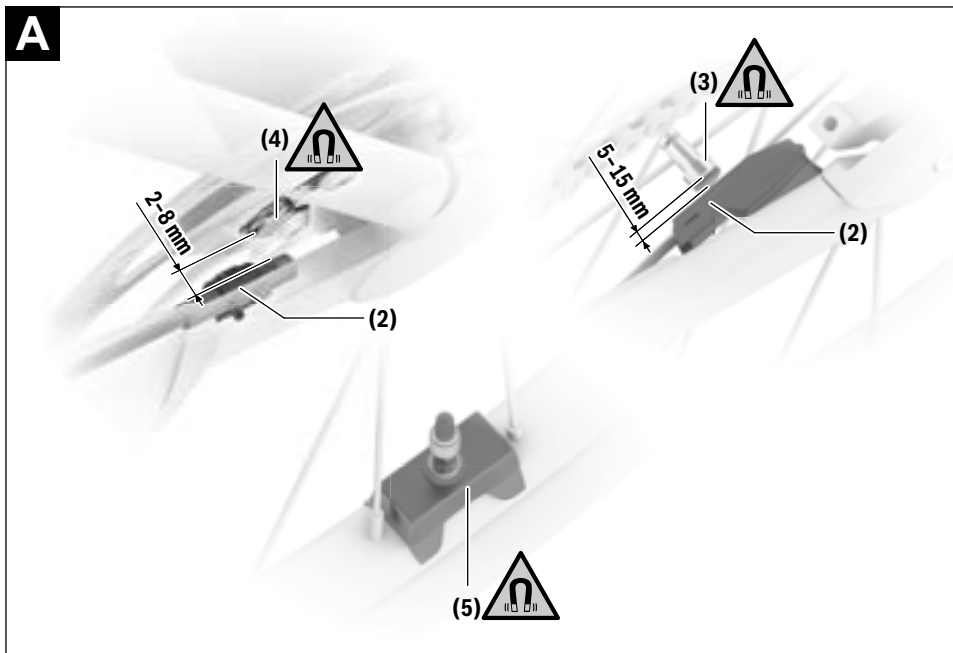
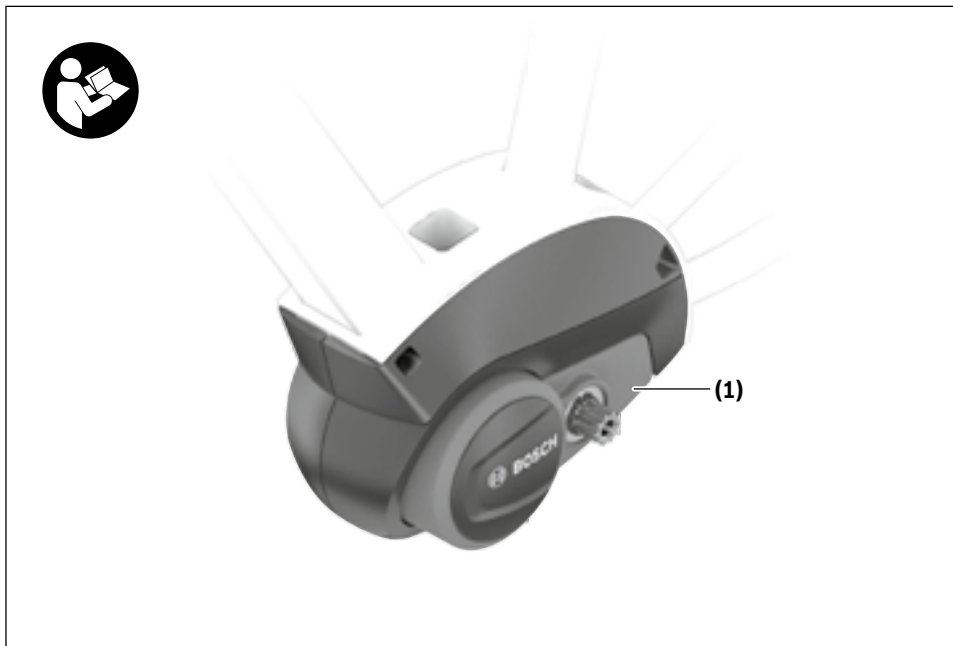

Safety instructions



Read all the safety information and instructions. Failure to observe the safety information and follow instructions may result in electric shock, fire and/or serious injury.

Save all safety warnings and instructions for future reference.

The term **battery** is used in these instructions to mean all original Bosch eBike rechargeable battery packs.

- ▶ **Read and observe the safety warnings and directions contained in all the eBike system operating instructions and in the operating instructions of your eBike.**
- ▶ **Do not attempt to change – and especially increase – the power of your drive or the maximum speed that it supports.** Doing this may put yourself and others at risk, and you may also breach statutory regulations.
- ▶ **Do not make any modifications to your eBike system or fit any other products that might increase the performance of your eBike system.** Doing so will generally reduce the service life of the system and risks damaging the drive unit and the bike. You also run the risk of losing the guarantee and warranty claims on the bicycle you have purchased. By handling the system improperly you are also endangering your safety and that of other road users, thus running the risk of high personal liability costs and possibly even criminal prosecution in the event of accidents that can be attributed to manipulation of the bicycle.

- ▶ **Do not open the drive unit yourself. The drive unit must only be repaired by qualified personnel using only original spare parts.** This will ensure that the safety of the drive unit is maintained. Unauthorised opening of the drive unit will render warranty claims null and void.
- ▶ **All components fitted to the drive unit and all other components of the eBike drive (e.g. chainring, chainring receptacle, pedals) must only be replaced with identical components or components that have been specifically approved by the manufacturer for your eBike.** This will protect the drive unit from overloading and becoming damaged.
- ▶ **Remove the battery from the eBike before beginning work (e.g. inspection, repair, assembly, maintenance, work on the chain, etc.) on the eBike, transporting it with a car or aeroplane, or storing it.** Unintentional activation of the eBike system poses a risk of injury.



On sections of the drive, temperatures > 60 °C may occur in extreme conditions, e.g. when carrying consistently high loads at low speed when riding up hills or transporting loads.

- ▶ **After a ride, do not allow your unprotected hands or legs to come into contact with the housing of the drive unit.** Under extreme conditions, such as continuously high torques at low travel speeds, or when riding up hills or carrying loads, the housing may reach a very high tem-

perature. The temperature that the drive unit housing may reach is influenced by the following factors:

- Ambient temperature
- Ride profile (route/gradient)
- Ride duration
- Assistance modes
- User behaviour (personal effort)
- Total weight (rider, eBike, luggage)
- Motor cover on the drive unit
- Heat dissipation properties of the bicycle frame
- Type of drive unit and type of gear-shifting

- ▶ **Use only original Bosch batteries that the manufacturer has approved for your eBike.** Using other batteries can lead to injuries and pose a fire hazard. Bosch accepts no liability or warranty claims if other batteries are used.



Keep the magnet away from implants and other medical devices, e.g. pacemakers or insulin pumps. The magnet generates a field that can impair the function of implants and medical devices.

- ▶ **Keep the magnet away from magnetic data carriers and magnetically sensitive devices.** The effect of the magnets may lead to irreversible data losses.
- ▶ **Observe all national regulations which set out the approved use of eBikes.**

Privacy notice

When you connect the eBike to the **Bosch DiagnosticTool 3**, data about Bosch drive unit (e.g. energy consumption, temperature, etc.) is transferred to Bosch eBike Systems (Robert Bosch GmbH) for the purposes of product improvement. You can find more information about this on the Bosch eBike website at www.bosch-ebike.com.



Product description and specifications

Intended use

The drive unit is intended exclusively for driving your eBike and must not be used for any other purpose.

In addition to the functions shown here, changes to software relating to troubleshooting and functional modifications may be introduced at any time.

Product features

Individual illustrations in these operating instructions may differ slightly from the actual conditions depending on the equipment of your eBike.

The numbering of the components shown refers to the illustrations on the graphics pages at the beginning of the manual.

- (1) Drive unit
- (2) Speed sensor^{a)}
- (3) Spoke magnet
- (4) CenterLock magnet^{b)}
- (5) Rim magnet

- a) different sensor type and installation position is possible
b) different installation position is possible

Technical data

Drive unit	Performance Line	
Product code		BDU3360
Continuous rated power	W	250
Torque at drive, max.	Nm	75
Rated voltage	V=	36
Operating temperature	°C	-5 to +40
Storage temperature	°C	+10 to +40
Protection rating		IP54
Weight, approx.	kg	3.2
The Bosch eBike system uses FreeRTOS (see http://www.freertos.org).		
Bicycle lights ^{A)}		
Voltage approx. ^{B)}	V=	12
Maximum power		
- Front light	W	17.4
- Tail light	W	0.6

A) Depends on legal regulations, not possible in all country-specific models via the eBike battery

B) When changing the bulbs, ensure that they are compatible with the Bosch eBike system (ask your bicycle dealer) and are suitable for the specified voltage. Bulbs must only be replaced with bulbs of the same voltage.

Inserting a bulb incorrectly can cause it to blow.

Information on the noise emissions of the drive unit

Typically, the A-weighted noise emission level of the eBike system is < 70 dB(A). A key feature of the eBike Alarm service is that the drive unit will emit an alarm tone in response to unauthorised movement of the eBike. This alarm tone can exceed a noise emission level of 70 dB(A) and measures 80 dB(A) at a 2 m distance from the drive unit. The alarm tone is only available once the eBike Alarm service has been activated and can be deactivated via the app eBike Flow.

Assembly

Checking the speed sensor (see figure A)

Speedsensor (slim)

The speed sensor (2) and its CenterLock magnet (4) or spoke magnet (3) are mounted ex works in such a manner that the magnet, after a turn of the wheel, moves past the speed sensor with a clearance of at least 2 mm, yet no more than 15 mm.

If any structural changes are made, the correct distance between the magnet and the sensor must be complied with (see figure A).

Note: Make sure you do not damage the sensor or the sensor holder when fitting or removing the rear wheel.

When changing a wheel, make sure that the sensor cable is routed so that it is not under tension and has no kinks.

The CenterLock magnet (4) can only be removed and reinserted up to five times.

Rim magnet

When installing a rim magnet, no sensor is required to detect a wheel turn. The drive unit itself detects when the magnet is close to it and calculates the speed and any other data required from the frequency of the emergence of the magnet field.

Since the drive unit is sensitive to magnetic fields, avoid other magnetic fields in the vicinity of the drive unit (e.g. magnetic clipless pedals, magnetic cadence sensors, etc.) in order to prevent disruption to the drive unit.

Operation

A control unit is required for the starting operation of the eBike system. Observe the starting operation for the eBike system and drive unit control in the control unit operating instructions.

Notes on cycling with the eBike system

When does the eBike drive work?

The eBike drive assists your cycling only when you are pedalling. If you do not pedal, the assistance will not work. The motor output always depends on the pedalling force you apply.

If you apply less force, you will receive less assistance than if you apply a lot of force. This applies irrespective of the assistance level.

The eBike drive automatically switches off at speeds over **20 mph**. When the speed falls below **20 mph**, the drive automatically becomes available again.

An exception applies to the push assistance function, in which the eBike can be pushed at low speed without pedalling. The pedals may rotate when the push assistance is in use.

You can also use the eBike as a normal bicycle without assistance at any time, either by switching off the eBike system or by setting the assistance level to **OFF**. The same applies when the battery is drained.

Interaction between the eBike system and gear-shifting

The gear-shifting should be used with an eBike drive in the same way as with a normal bicycle (observe the operating instructions of your eBike on this point).

Irrespective of the type of gear-shifting, it is advisable to briefly stop pedalling when changing gear. This will facilitate the gear change and reduce wear on the powertrain.

By selecting the correct gear, you can increase your speed and range while applying the same amount of force.

Gaining initial experience

We recommend that you gain initial experience with the eBike away from busy roads.

Test the various assistance levels, beginning with the lowest level. As soon as you feel confident, you can ride your eBike in traffic like any other bicycle.

Test the range of your eBike in different conditions before planning longer and more demanding trips.

Influences on range

The range is affected by a number of factors, such as:

- Assistance level
- Speed
- Gear shifting behaviour
- Tyre type and tyre pressure
- Age and condition of the battery
- Route profile (gradients) and conditions (road surface)
- Headwind and ambient temperature
- Weight of eBike, rider and luggage

For this reason, it is not possible to predict the range accurately before and during a trip. However, as a general rule:

- With the **same** assistance level on the eBike drive: The less energy you need to exert in order to reach a certain speed (e.g. by changing gears optimally), the less energy the eBike drive will consume and the higher the range per battery charge will be.
- The **higher** the selected assistance level under otherwise constant conditions, the smaller the range will be.

Taking care of your eBike

Please observe the operating and storage temperatures of the eBike components. Protect the drive unit, on-board computer and battery against extreme temperatures (e.g. from intense sunlight without adequate ventilation). Extreme tem-

peratures can cause the components (especially the battery) to become damaged.

Have your eBike system checked by an expert at least once a year (including mechanical parts, up-to-dateness of system software).

Maintenance and servicing

Maintenance and cleaning

When changing the bulbs, ensure that they are compatible with the Bosch eBike system (ask your bicycle dealer) and are suitable for the specified voltage. Bulbs must only be replaced with bulbs of the same voltage.

Do not immerse any components, including the drive unit, in water or clean them with pressurised water.

Have your eBike system checked by an expert at least once a year (including mechanical parts, up-to-dateness of system software).

Please have your eBike serviced and repaired by an authorised bicycle dealer.

After-sales service and advice on using products

If you have any questions about the eBike system and its components, contact an authorised bicycle dealer.

For contact details of authorised bike dealerships, please visit www.bosch-ebike.com.

Disposal



The drive unit, on-board computer incl. operating unit, battery, speed sensor, accessories and packaging should be disposed of in an environmentally correct manner.

Check that your personal data has been deleted from the device.

Do not dispose of eBikes and their components with household waste.



In accordance with Directive 2012/19/EU and Directive 2006/66/EC respectively, electronic devices that are no longer usable and defective/drained batteries must be collected separately and recycled in an environmentally friendly manner.

Please return Bosch eBike components that are no longer usable free of charge to an authorised bicycle dealer or to a recycling facility.

Subject to change without notice.



6.2 Drive CX/Cargo/CX Race Edition/Speed

BDU3740 | BDU3741 | BDU3760 |
BDU3761 | BDU3780 | BDU3781

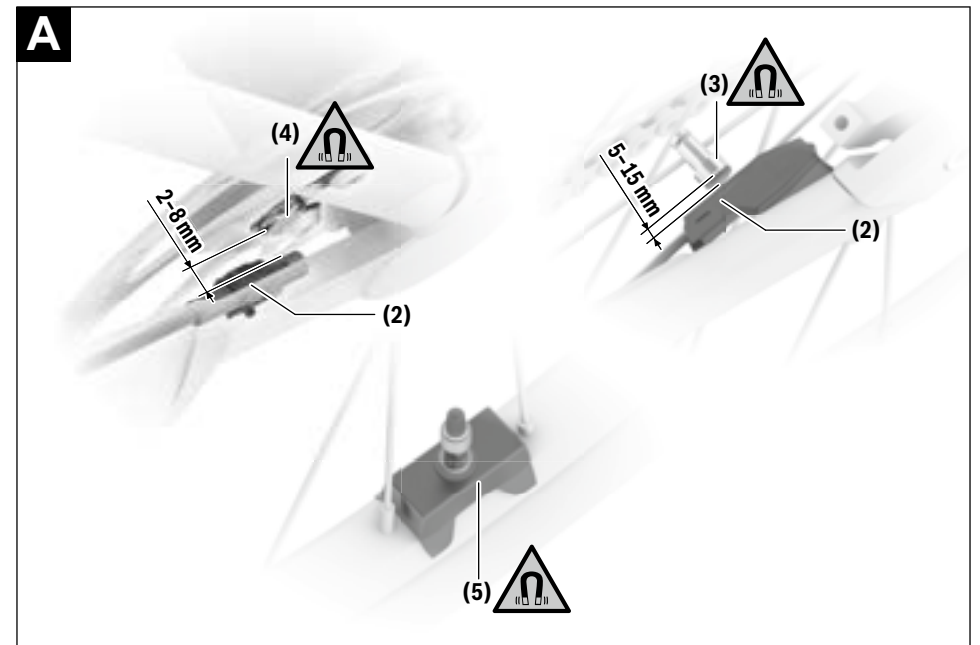
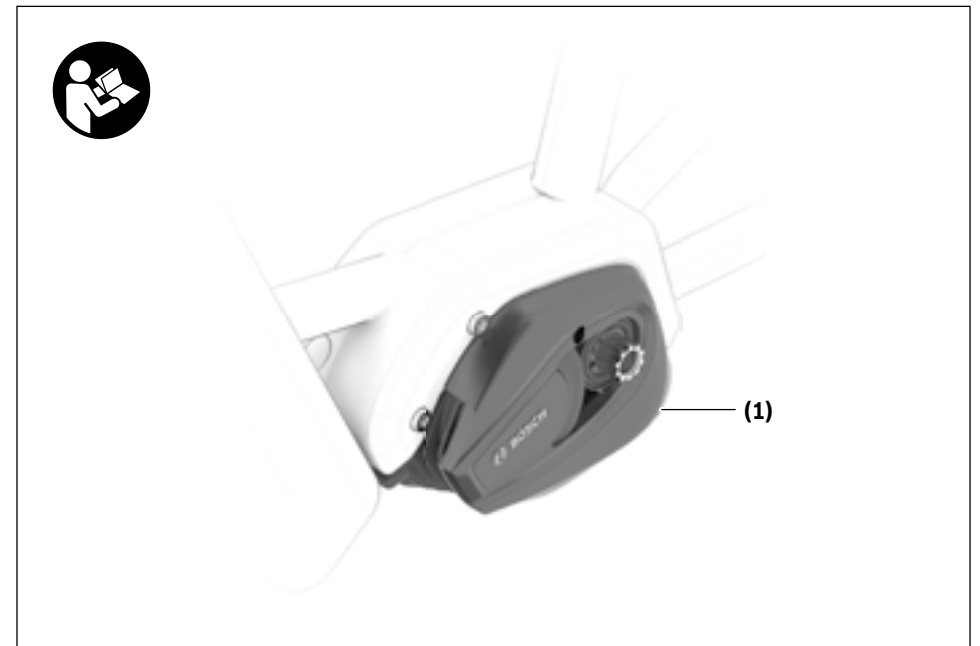

Safety instructions



Read all the safety information and instructions. Failure to observe the safety information and follow instructions may result in electric shock, fire and/or serious injury.

Save all safety warnings and instructions for future reference.

The term **battery** is used in these instructions to mean all original Bosch eBike rechargeable battery packs.

- ▶ **Read and observe the safety warnings and directions contained in all the eBike system operating instructions and in the operating instructions of your eBike.**
- ▶ **Do not attempt to change – and especially increase – the power of your drive or the maximum speed that it supports.** Doing this may put yourself and others at risk, and you may also breach statutory regulations.
- ▶ **Do not make any modifications to your eBike system or fit any other products that might increase the performance of your eBike system.** Doing so will generally reduce the service life of the system and risks damaging the drive unit and the bike. You also run the risk of losing the guarantee and warranty claims on the bicycle you have purchased. By handling the system improperly you are also endangering your safety and that of other road users, thus running the risk of high personal liability costs and possibly even criminal prosecution in the event of accidents that can be attributed to manipulation of the bicycle.

- ▶ **Do not open the drive unit yourself. The drive unit must only be repaired by qualified personnel using only original spare parts.** This will ensure that the safety of the drive unit is maintained. Unauthorised opening of the drive unit will render warranty claims null and void.
- ▶ **All components fitted to the drive unit and all other components of the eBike drive (e.g. chainring, chainring receptacle, pedals) must only be replaced with identical components or components that have been specifically approved by the manufacturer for your eBike.** This will protect the drive unit from overloading and becoming damaged.
- ▶ **Remove the battery from the eBike before beginning work (e.g. inspection, repair, assembly, maintenance, work on the chain, etc.) on the eBike, transporting it with a car or aeroplane, or storing it.** Unintentional activation of the eBike system poses a risk of injury.



On sections of the drive, temperatures > 60 °C may occur in extreme conditions, e.g. when carrying consistently high loads at low speed when riding up hills or transporting loads.

- ▶ **After a ride, do not allow your unprotected hands or legs to come into contact with the housing of the drive unit.** Under extreme conditions, such as continuously high torques at low travel speeds, or when riding up hills or carrying loads, the housing may reach a very high tem-

perature.
The temperature that the drive unit housing may reach is influenced by the following factors:

- Ambient temperature
- Ride profile (route/gradient)
- Ride duration
- Assistance modes
- User behaviour (personal effort)
- Total weight (rider, eBike, luggage)
- Motor cover on the drive unit
- Heat dissipation properties of the bicycle frame
- Type of drive unit and type of gear-shifting

- ▶ **Use only original Bosch batteries that the manufacturer has approved for your eBike.** Using other batteries can lead to injuries and pose a fire hazard. Bosch accepts no liability or warranty claims if other batteries are used.



Keep the magnet away from implants and other medical devices, e.g. pacemakers or insulin pumps. The magnet generates a field that can impair the function of implants and medical devices.

- ▶ **Keep the magnet away from magnetic data carriers and magnetically sensitive devices.** The effect of the magnets may lead to irreversible data losses.
- ▶ **Observe all national regulations which set out the approved use of eBikes.**

Privacy notice

When you connect the eBike to the **Bosch DiagnosticTool 3**, data about Bosch drive unit (e.g. energy consumption, temperature, etc.) is transferred to Bosch eBike Systems (Robert Bosch GmbH) for the purposes of product improvement. You can find more information about this on the Bosch eBike website at www.bosch-ebike.com.

Product description and specifications

Intended use

The drive unit is intended exclusively for driving your eBike and must not be used for any other purpose.

In addition to the functions shown here, changes to software relating to troubleshooting and functional modifications may be introduced at any time.

Product features

Individual illustrations in these operating instructions may differ slightly from the actual conditions depending on the equipment of your eBike.

The numbering of the components shown refers to the illustrations on the graphics pages at the beginning of the manual.

- (1) Drive unit
- (2) Speed sensor ^{a)}
- (3) Spoke magnet
- (4) CenterLock magnet ^{b)}
- (5) Rim magnet

- a) different sensor type and installation position is possible
- b) different installation position is possible

Technical data

Drive unit	Drive Unit Performance Line CX/Cargo/CX Race Edition/Speed	
Product code		BDU3740 BDU3741 BDU3760 BDU3761 BDU3780 BDU3781
Continuous rated power	W	250
Torque at drive, max.	Nm	85
Rated voltage	V=	36
Operating temperature	°C	-5 to +40
Storage temperature	°C	+10 to +40
Protection rating		IP54
Weight, approx.	kg	3

The Bosch eBike system uses FreeRTOS (see <http://www.freertos.org>).

Bicycle lights ^{A)}		
Voltage approx. ^{B)}	V=	12
Maximum power		
– Front light	W	17.4

Bicycle lights ^{A)}		
– Tail light	W	0.6

A) Depends on legal regulations, not possible in all country-specific models via the eBike battery

B) When changing the bulbs, ensure that they are compatible with the Bosch eBike system (ask your bicycle dealer) and are suitable for the specified voltage. Bulbs must only be replaced with bulbs of the same voltage.

Inserting a bulb incorrectly can cause it to blow.

Information on the noise emissions of the drive unit

Typically, the A-weighted noise emission level of the eBike system is < 70 dB(A). A key feature of the **<eBike Alarm>** service is that the drive unit will emit an alarm tone in response to unauthorised movement of the eBike. This alarm tone can exceed a noise emission level of 70 dB(A) and measures 80 dB(A) at a 2 m distance from the drive unit. The alarm tone is only available once the **<eBike Alarm>** service has been activated and can be deactivated via the app **eBike Flow**.

Assembly

Checking the speed sensor (see figure A)

Speedsensor (slim)

The speed sensor (2) and its CenterLock magnet (4) or spoke magnet (3) are mounted ex works in such a manner that the magnet, after a turn of the wheel, moves past the speed sensor with a clearance of at least 2 mm, yet no more than 15 mm.

If any structural changes are made, the correct distance between the magnet and the sensor must be complied with (see figure A).

Note: Make sure you do not damage the sensor or the sensor holder when fitting or removing the rear wheel.

When changing a wheel, make sure that the sensor cable is routed so that it is not under tension and has no kinks.

The CenterLock magnet (4) can only be removed and reinserted up to five times.

Rim magnet

When installing a rim magnet, no sensor is required to detect a wheel turn. The drive unit itself detects when the magnet is close to it and calculates the speed and any other data required from the frequency of the emergence of the magnet field.

Since the drive unit is sensitive to magnetic fields, avoid other magnetic fields in the vicinity of the drive unit (e.g. magnetic clipless pedals, magnetic cadence sensors, etc.) in order to prevent disruption to the drive unit.

Operation

A control unit is required for the starting operation of the eBike system. Observe the starting operation for the eBike



system and drive unit control in the control unit operating instructions.

Notes on cycling with the eBike system

When does the eBike drive work?

The eBike drive assists your cycling only when you are pedalling. If you do not pedal, the assistance will not work. The motor output always depends on the pedalling force you apply.

If you apply less force, you will receive less assistance than if you apply a lot of force. This applies irrespective of the assistance level.

The eBike drive automatically switches off at speeds over **20/28 mph**. When the speed falls below **20/28 mph**, the drive automatically becomes available again.

An exception applies to the push assistance function, in which the eBike can be pushed at low speed without pedalling. The pedals may rotate when the push assistance is in use.

You can also use the eBike as a normal bicycle without assistance at any time, either by switching off the eBike system or by setting the assistance level to **OFF**. The same applies when the battery is drained.

Interaction between the eBike system and gear-shifting

The gear-shifting should be used with an eBike drive in the same way as with a normal bicycle (observe the operating instructions of your eBike on this point).

Irrespective of the type of gear-shifting, it is advisable to briefly stop pedalling when changing gear. This will facilitate the gear change and reduce wear on the powertrain.

By selecting the correct gear, you can increase your speed and range while applying the same amount of force.

Gaining initial experience

We recommend that you gain initial experience with the eBike away from busy roads.

Test the various assistance levels, beginning with the lowest level. As soon as you feel confident, you can ride your eBike in traffic like any other bicycle.

Test the range of your eBike in different conditions before planning longer and more demanding trips.

Influences on range

The range is affected by a number of factors, such as:

- Assistance level
- Speed
- Gear shifting behaviour
- Tyre type and tyre pressure
- Age and condition of the battery
- Route profile (gradients) and conditions (road surface)
- Headwind and ambient temperature
- Weight of eBike, rider and luggage

For this reason, it is not possible to predict the range accurately before and during a trip. However, as a general rule:

- With the **same** assistance level on the eBike drive: The less energy you need to exert in order to reach a certain speed (e.g. by changing gears optimally), the less energy the eBike drive will consume and the higher the range per battery charge will be.
- The **higher** the selected assistance level under otherwise constant conditions, the smaller the range will be.

Taking care of your eBike

Please observe the operating and storage temperatures of the eBike components. Protect the drive unit, on-board computer and battery against extreme temperatures (e.g. from intense sunlight without adequate ventilation). Extreme temperatures can cause the components (especially the battery) to become damaged.

Have your eBike system checked by an expert at least once a year (including mechanical parts, up-to-dateness of system software).

Maintenance and servicing

Maintenance and cleaning

When changing the bulbs, ensure that they are compatible with the Bosch eBike system (ask your bicycle dealer) and are suitable for the specified voltage. Bulbs must only be replaced with bulbs of the same voltage.

Do not immerse any components, including the drive unit, in water or clean them with pressurised water.

Have your eBike system checked by an expert at least once a year (including mechanical parts, up-to-dateness of system software).

Please have your eBike serviced and repaired by an authorised bicycle dealer.

After-sales service and advice on using products

If you have any questions about the eBike system and its components, contact an authorised bicycle dealer.

For contact details of authorised bike dealerships, please visit www.bosch-ebike.com.

Disposal



The drive unit, on-board computer incl. operating unit, battery, speed sensor, accessories and packaging should be disposed of in an environmentally correct manner.

Check that your personal data has been deleted from the device.

Do not dispose of eBikes and their components with household waste.



In accordance with Directive 2012/19/EU and Directive 2006/66/EC respectively, electronic devices that are no longer usable and defective/drained batteries must be collected separately and recycled in an environmentally friendly manner.

Please return Bosch eBike components that are no longer usable free of charge to an authorised bicycle dealer or to a recycling facility.

Subject to change without notice.



7 Display

7.1 Kiox 300

BHU3600

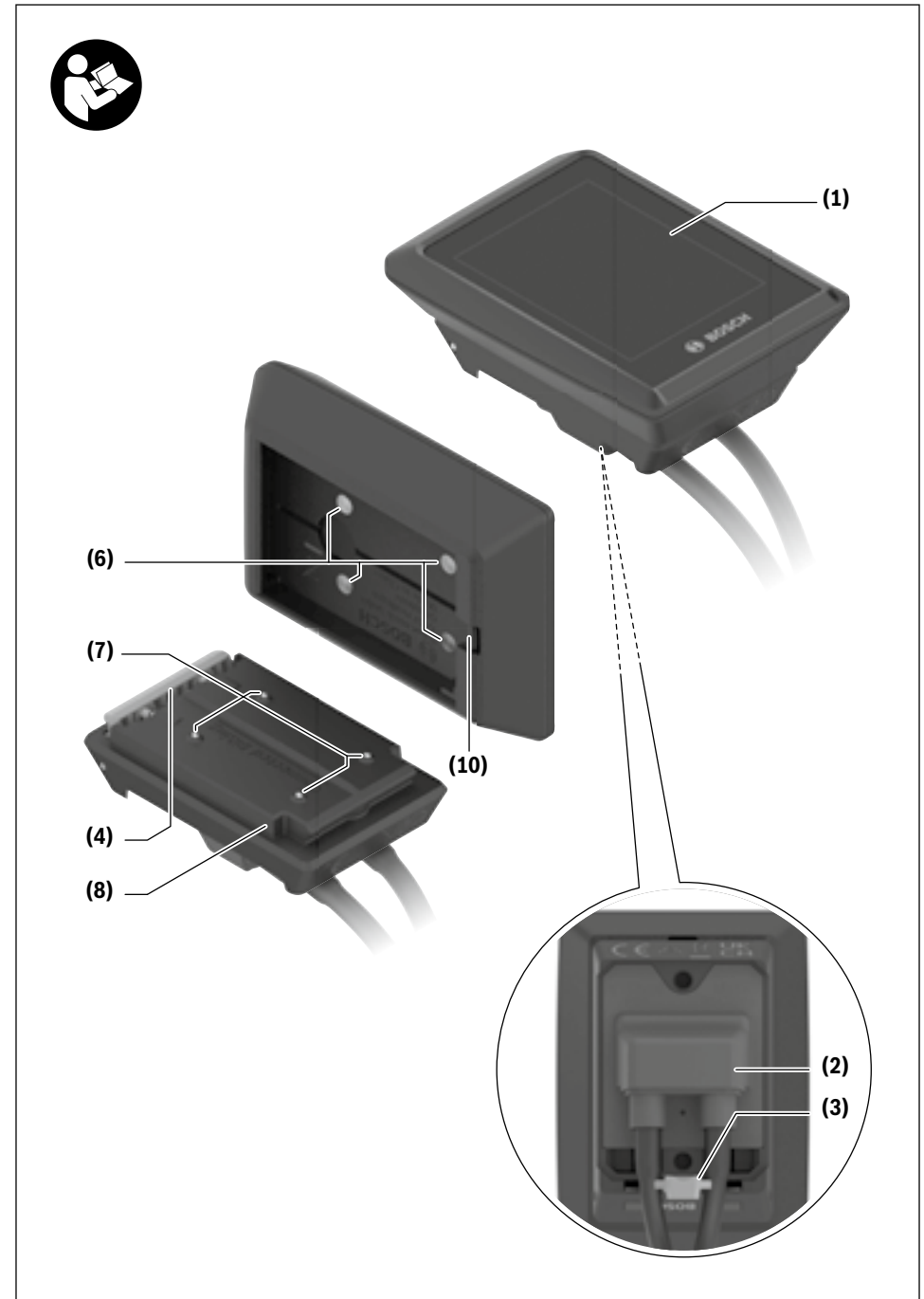
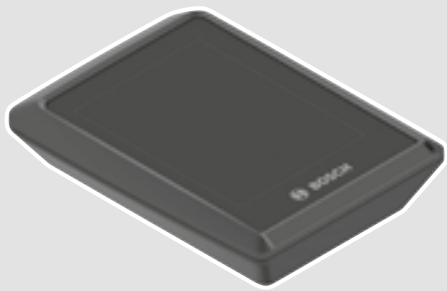

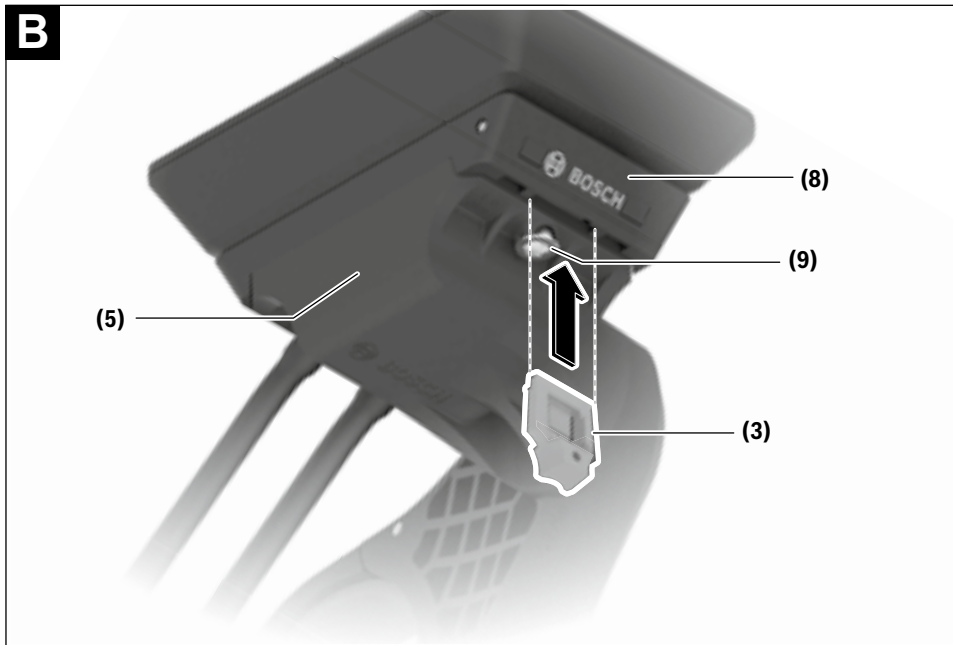
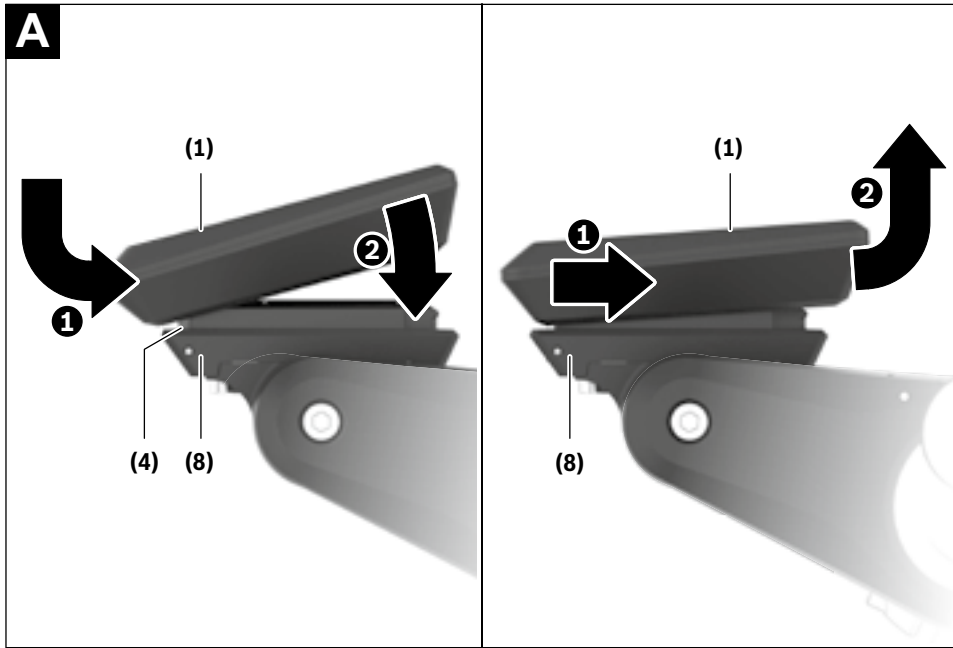

Safety instructions



Read all the safety information and instructions. Failure to observe the safety information and follow instructions may result in electric shock, fire and/or serious injury.

Save all safety warnings and instructions for future reference.

The term **battery** is used in these instructions to mean all original Bosch eBike rechargeable battery packs.

- ▶ **Read and observe the safety warnings and directions contained in all the eBike system operating instructions and in the operating instructions of your eBike.**
- ▶ **Do not attempt to secure the display or operating unit while riding.**
- ▶ **Do not allow yourself to be distracted by the on-board computer's display.** If you do not focus exclusively on the traffic, you risk being involved in an accident. If you want to make entries in your on-board computer other than switching the assistance level, stop and enter the appropriate data.
- ▶ **Do not use your smartphone while riding.** If you do not focus exclusively on the traffic, you risk being involved in an accident. Only enter the relevant data having stopped first.
- ▶ **Set the display brightness so that you can adequately see important information such as speed and warning symbols.** Incorrectly set display brightness may lead to dangerous situations.
- ▶ **Do not open the on-board computer.** Opening the on-board computer may damage it beyond repair and void any warranty claims.
- ▶ **Do not use the on-board computer as a handle.** Lifting the eBike up by the on-board computer can cause irreparable damage to the on-board computer.
- ▶ **Do not stand your bicycle upside down on its saddle and handlebars if the on-board computer or its holder protrude from the handlebars.** This may irreparably damage the on-board computer or the holder. Also remove the on-board computer before placing the bicycle on a wall mount to ensure that the on-board computer does not fall off or become damaged.

Privacy notice

If the on-board computer is sent to Bosch Service because it requires servicing, the data stored on the on-board computer may be transmitted to Bosch.

Product description and specifications

Intended use

The **Kiox 300** on-board computer is designed to display cycling data.

To access the full functionality of the **Kiox 300** on-board computer, you will need a compatible smartphone installed with the **eBike Flow** app (available from the Apple App Store or the Google Play Store).

Product features

The numbering of the components shown refers to the illustrations on the graphics pages at the beginning of the manual.

- (1) Display
- (2) Cable outlet
- (3) Removal blocker
- (4) Snap-in hook
- (5) Adapter tray
- (6) Display contacts
- (7) Holder contacts
- (8) Display mount
- (9) Display mount fastening screw
- (10) Bridge for retaining strap^{a)}

a) The retaining strap is not included in the scope of delivery.

Technical data

On-board computer	Kiox 300	
Product code		BHU3600
Operating temperature ^{A)}	°C	-5 to +40
Storage temperature	°C	+10 to +40
Protection rating		IP54
Weight, approx.	g	32

A) Temperatures outside of this range may cause faults in the display.

The licence information for the product can be accessed at the following Internet address: <https://www.bosch-ebike.com/licences>

UK
CA



Assembly

Fitting and Removing the Display (see figure A)

To fit the display (1), attach the display (1) to the front edge of the display mount (8) in the direction of travel, on the snap-in hook (4) and press the rear side of the display (1) on the display mount (8).

To remove the display (1), pull the display (1) towards you until you are able to lift off the display (1).

A retaining strap can be secured to the bridge (10).

Note: The eBike system will switch off if you are riding at under 3 km/h and remove the on-board computer from its holder. This does not apply to eBikes with assistance up to 28 mph.

Inserting the Removal Blocker (see figure B)

Note: Depending on the design/mounting of the display mount, it may not be possible to insert the removal blocker. The display must be mounted.

Insert the removal blocker (3) into the adapter tray (5) from below until you hear the removal blocker (3) click into place.

From this point onwards, you can no longer lift off the display (1) from the display fixture (8) without removing the display mount (8) from the adapter tray (5) by loosening the two fastening screws (9).

Note: The removal blocker (3) is not an anti-theft device.

Operation

The displays are operated and the indicators are controlled via a control unit.

The meaning of the buttons on the operating unit for the display indicators can be found in the following overview. Depending on how long it is pressed for, the select button has two functions.

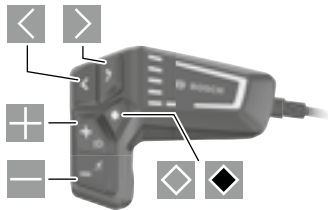

- ◀ Scroll to the left
- ▶ Scroll to the right
- ⊕ Scroll up
- ⊖ Scroll down
- ◊ Change to the second page level (press briefly)
Open the settings menu on the status page (press briefly)
- ◊ Open page-related options
e.g. Reset trip (press and hold > 1 s)

Please note: All screenshots showing the display and text on the following pages are from the approved software version. The display and/or text may change slightly following a software update.

Status page

From the start page, you can access the status page by pressing the button.

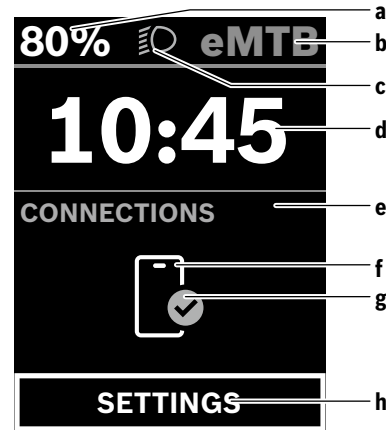

- a Battery charge
- b Assistance level
- c Bicycle lights
- d Time
- e Connection indicator
- f Smartphone connection
- g Connection status
- h Settings Menu

You can access the settings menu from this page by pressing the button.

Note: The settings menu cannot be called up while riding.

The SETTINGS settings menu contains the following menu items:

- My eBike
You can find the following menu items here.
 - Range reset
The value for the range can be reset here.
 - Auto trip reset
The settings for automatic reset can be adjusted here.
 - Wheel circumf.
The value of the wheel circumference can be adjusted or reset to the standard setting here.
 - Service
The next service date is shown here, provided that it has been set by the bicycle dealer.
 - Components
The components used with their version numbers are displayed here.

- My Kiox
You can find the following menu items here.
 - Statusbar
You can choose between the Battery, Time or Speed displays here.
 - Language
You can select your preferred system language here.
 - Units
You can choose between metric or imperial measurements here.
 - Time
You can set the time here.
 - Time format
You can select one of the two time formats here.
 - Brightness
You can set the display brightness here.
 - Settings reset
You can reset all of the system settings to the default values here.
- Under the Information menu item, you will find the contact details (Contact) and certificates (Certificates).

You can leave the settings menu by pressing the button or the button.

Press the button to access the start page.

Start page

If you did not select another page before the last time you switched off, you will be shown this page.

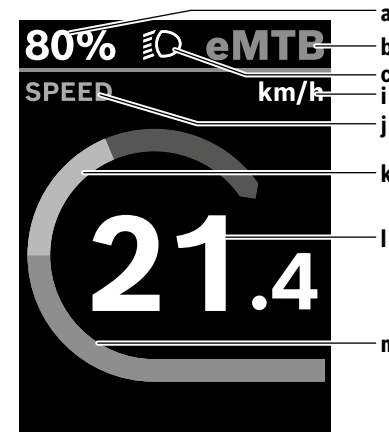

- a Battery charge
- b Assistance level
- c Bicycle lights
- i Unit of speed indicator
- j Indicator name
- k Your performance
- l Speed
- m Motor output

The a ... c indicators form the status bar and are shown on every page.

You can use the button to change from this page to the status page or press the button to access additional pages. The statistical data, battery range and average values are displayed on these pages.

From each of these pages, you can access the second level of data by pressing the button.

If the user is on a different page to the start page when they switch off, the most recently displayed page will appear again when the eBike is switched on.

Pressing and holding the select button enables you to reset the statistical data for your journey or excursion (not on the SETTINGS page).

Maintenance and servicing

Maintenance and cleaning

Do not clean any of the components with pressurised water. Keep the screen of your on-board computer clean. Dirt can cause faulty brightness detection.

Clean your on-board computer using a soft cloth dampened only with water. Do not use cleaning products of any kind.

Have your eBike system checked by an expert at least once a year (including mechanical parts, up-to-dateness of system software).

In addition, the bicycle dealer may base the service date on the distance travelled and/or on a period of time. In this case, the on-board computer displays a message telling you when the service date is due each time it is switched on.

Please have your eBike serviced and repaired by an authorised bicycle dealer.

▶ **Have all repairs performed only by an authorised bike dealer.**

Note: If you are handing in your eBike to a bicycle dealer for maintenance, it is recommended that you temporarily deactivate the eBike Lock and eBike Alarm to prevent false alarms.

After-sales service and advice on using products

If you have any questions about the eBike system and its components, contact an authorised bicycle dealer.

For contact details of authorised bike dealerships, please visit www.bosch-ebike.com.

Transport

▶ **If you transport your eBike attached to the outside of your car, e.g. on a bike rack, remove the on-board computer and the eBike battery to avoid damaging them.**

Disposal



The drive unit, on-board computer incl. operating unit, battery, speed sensor, accessories

and packaging should be disposed of in an environmentally correct manner.

Check that your personal data has been deleted from the device.

Do not dispose of eBikes and their components with household waste.



In accordance with Directive 2012/19/EU and Directive 2006/66/EC respectively, electronic devices that are no longer usable and defective/drained batteries must be collected separately and recycled in an environmentally friendly manner.

Please return Bosch eBike components that are no longer usable free of charge to an authorised bicycle dealer or to a recycling facility.

Subject to change without notice.

7.2 Intuvia 100

BHU3200



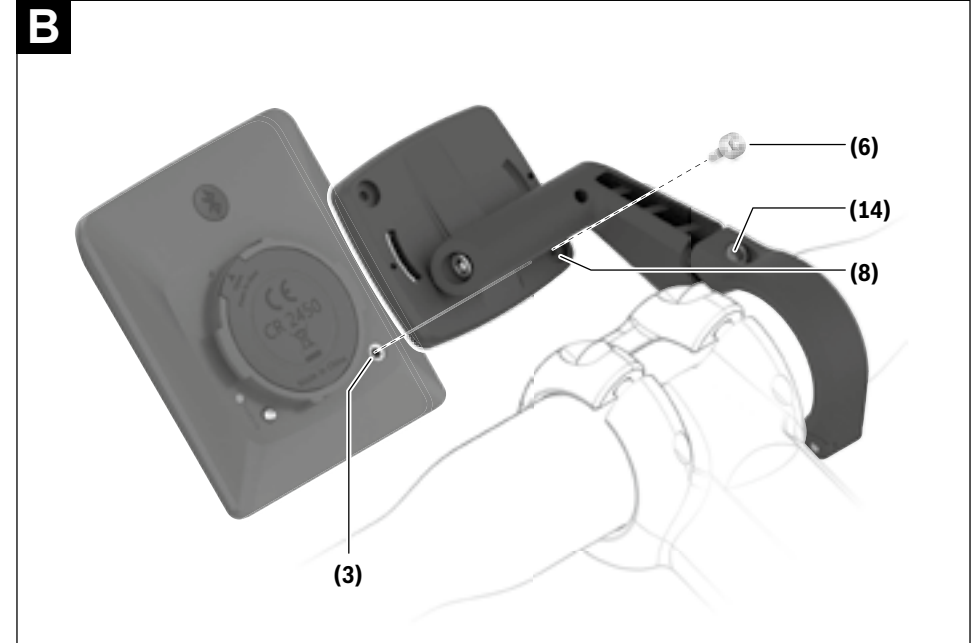
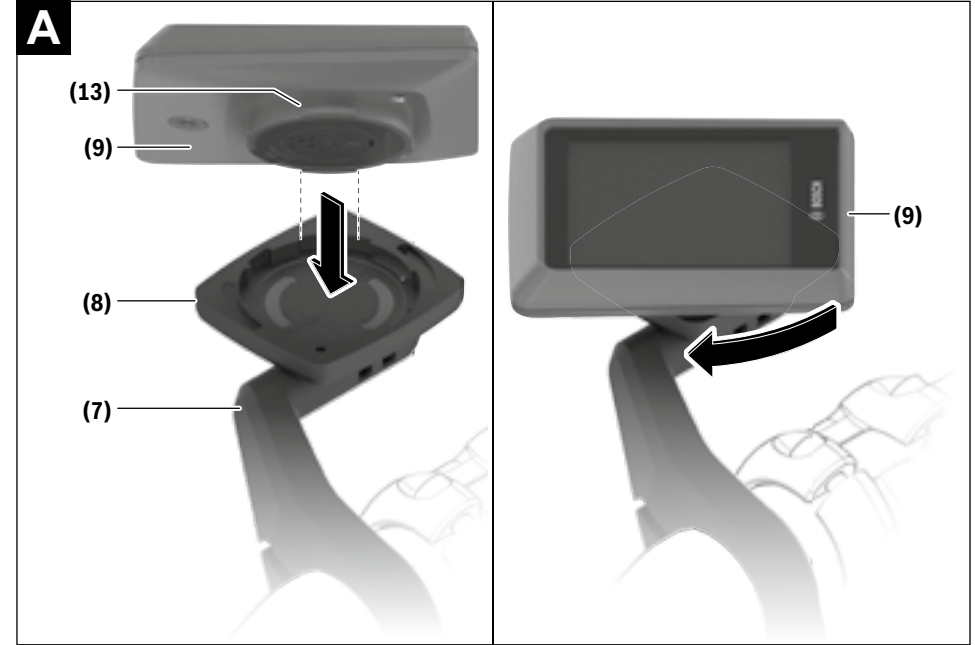
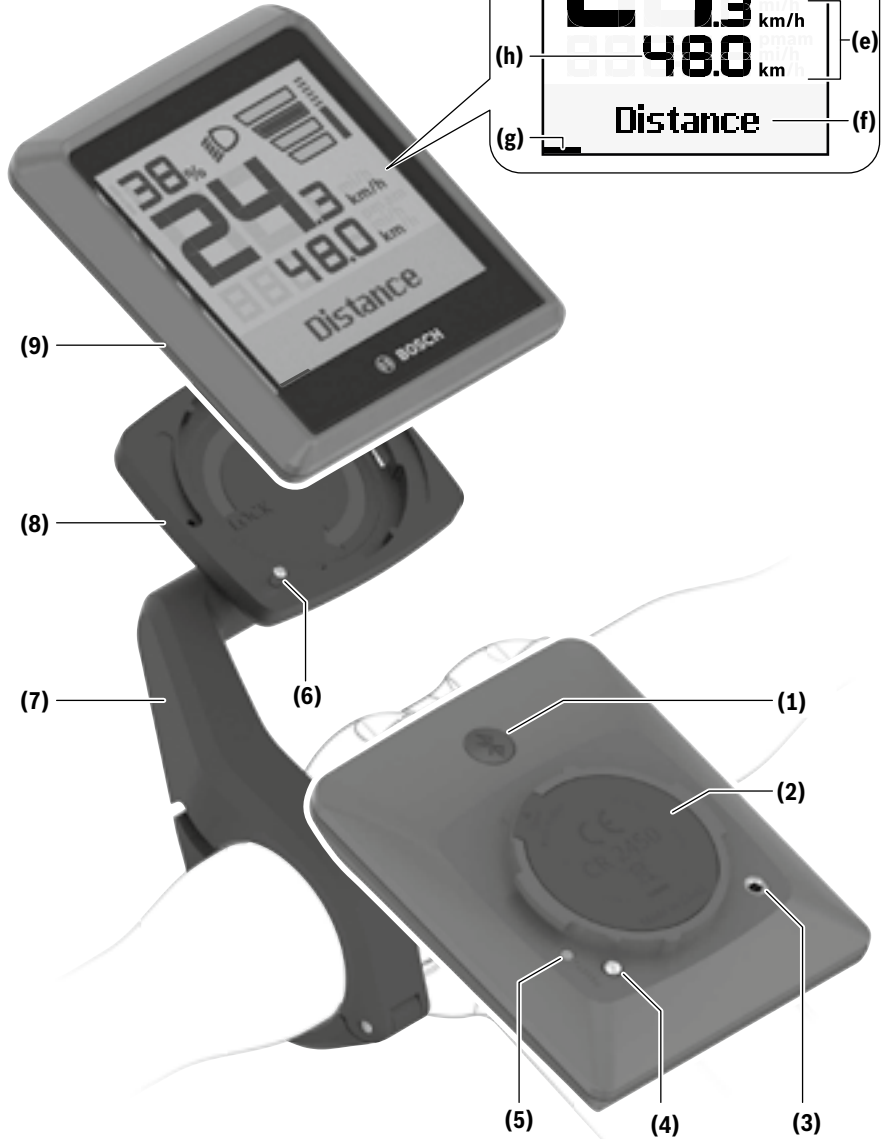

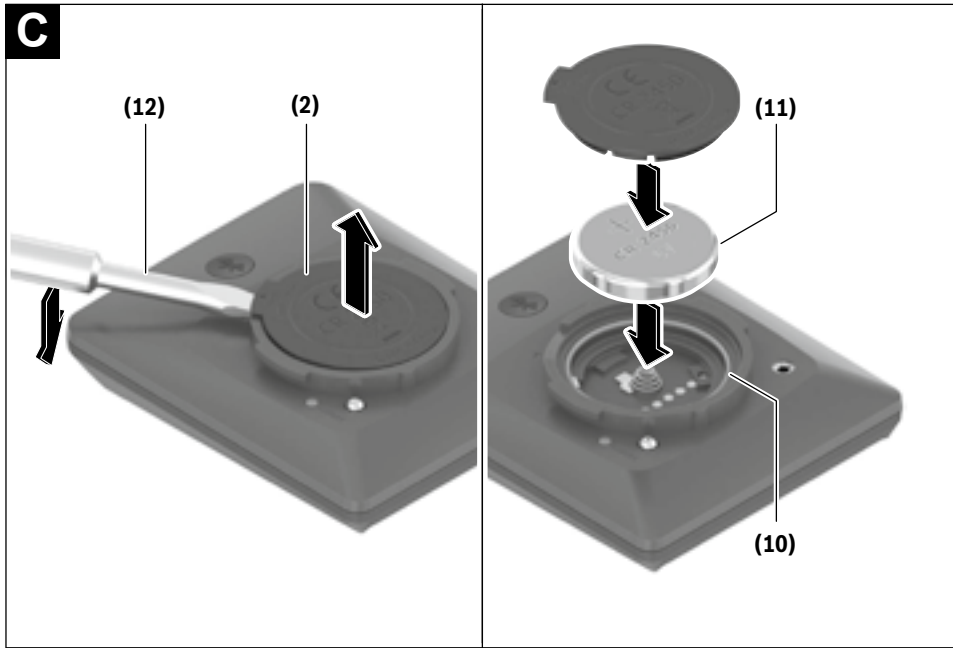

Safety instructions



Read all the safety information and instructions. Failure to observe the safety information and follow instructions may result in electric shock, fire and/or serious injury.

Save all safety warnings and instructions for future reference.

The term **battery** is used in these instructions to mean all original Bosch eBike rechargeable battery packs.

- ▶ **Read and observe the safety warnings and directions contained in all the eBike system operating instructions and in the operating instructions of your eBike.**
- ▶ **Do not attempt to secure the display or operating unit while riding.**
- ▶ **Do not allow yourself to be distracted by the on-board computer's display.** If you do not focus exclusively on the traffic, you risk being involved in an accident. If you want to make entries in your on-board computer other than switching the assistance level, stop and enter the appropriate data.
- ▶ **Do not use your smartphone while riding.** If you do not focus exclusively on the traffic, you risk being involved in an accident. Only enter the relevant data having stopped first.
- ▶ **Set the display brightness so that you can adequately see important information such as speed and warning symbols.** Incorrectly set display brightness may lead to dangerous situations.
- ▶ **Do not open the on-board computer.** Opening the on-board computer may damage it beyond repair and void any warranty claims.
- ▶ **Do not use the on-board computer as a handle.** Lifting the eBike up by the on-board computer can cause irreparable damage to the on-board computer.
- ▶ **Do not stand your bicycle upside down on its saddle and handlebars if the on-board computer or its holder protrude from the handlebars.** This may irreparably damage the on-board computer or the holder. Also remove the on-board computer before placing the bicycle on a wall mount to ensure that the on-board computer does not fall off or become damaged.
- ▶ **Caution!** When using the on-board computer with *Bluetooth*® and/or WiFi, interference can occur with other devices and equipment, aircraft and medical devices (e.g. pacemakers, hearing aids). Likewise, injury to people and animals in the immediate vicinity cannot be excluded entirely. Do not use the on-board computer with *Bluetooth*® in the vicinity of medical devices, petrol stations, chemical plants, areas with a potentially explosive atmosphere or on blast sites. Do not use the on-board computer with *Bluetooth*® in aeroplanes. Avoid using the on-board computer near your body for extended periods.
- ▶ The *Bluetooth*® word mark and logos are registered trademarks owned by Bluetooth SIG, Inc. and any use of such marks by Bosch eBike Systems is under licence.

- ▶ **The on-board computer is equipped with a wireless interface. Local operating restrictions, e.g. in aeroplanes or hospitals, must be observed.**

Safety instructions for coin cells

- ▶ **WARNING! Ensure that the coin cell is kept out of the reach of children.** Coin cells are dangerous.
- ▶ **Coin cells must never be swallowed or inserted into any other part of the body. If you suspect that someone has swallowed a coin cell or that a coin cell has entered the body in another way, seek medical attention immediately.** Swallowing coin cells can result in severe internal burns and death within two hours.
- ▶ **Ensure that coin cell replacement is carried out properly.** There is a risk of explosion.
- ▶ **Only use the coin cells listed in this operating manual.** Do not use any other coin cells or other forms of electrical power supply.
- ▶ **Do not attempt to recharge the coin cell and do not short circuit the coin cell.** The coin cell may leak, explode, catch fire and cause personal injury.
- ▶ **Remove and dispose of drained coin cells correctly.** Drained coin cells may leak and cause personal injury or damage the product.
- ▶ **Do not overheat the coin cell or throw it into fire.** The coin cell may leak, explode, catch fire and cause personal injury.
- ▶ **Do not damage the coin cell and or take the coin cell apart.** The coin cell may leak, explode, catch fire and cause personal injury.
- ▶ **Do not allow damaged coin cells to come into contact with water.** Leaking lithium may mix with water to create hydrogen, which could cause a fire, an explosion, or personal injury.
- ▶ **Only for Australia**



Caution! Battery is hazardous and is to be kept away from children (whether the battery is new or used). Battery can cause severe or fatal injuries in 2 hours or less if it is swallowed or placed inside any part of the body. Medical attention should be sought immediately if it is suspected the battery has been swallowed or placed inside any part of the body.

Privacy notice

If the on-board computer is sent to Bosch Service because it requires servicing, the data stored on the on-board computer may be transmitted to Bosch.



Product Description and Specifications

Intended Use

The **Intuvia 100** on-board computer is designed to display cycling data.

To access the full functionality of the eBike system and **Intuvia 100** on-board computer, you will need a compatible smartphone installed with the **eBike Flow** app (available from the Apple App Store or the Google Play Store), e.g. for **<Reset trip>**.

Product Features

The numbering of the components shown refers to the illustrations on the graphics pages at the beginning of the manual.

- (1) *Bluetooth*[®] button
 - (2) Battery compartment cover
 - (3) Locking screw support
 - (4) On-board computer contact
 - (5) Reset button
 - (6) Locking screw for on-board computer
 - (7) Holder for on-board computer
 - (8) On-board computer cradle
 - (9) On-board computer
 - (10) Rubber seal
 - (11) Non-rechargeable battery (coin cell type CR2450)
 - (12) Slotted screwdriver^{a)}
 - (13) Battery compartment
 - (14) Holder fastening screw
- a) Not included in the scope of delivery

Display Elements of On-Board Computer

- (a) Battery charge indicator
- (b) Bike lights display
- (c) Assistance level indicator
- (d) Drive unit assistance indicator
- (e) Unit indicator
- (f) Text indicator
- (g) Navigation bar
- (h) Value indicator
- (i) Speedometer

Technical Data

On-board computer	Intuvia 100	
Product code	BHU3200	
Operating temperature ^{A)}	°C	-5 to +40
Storage temperature	°C	+10 to +40
Battery	1× CR2450	

On-board computer	Intuvia 100	
Protection rating	IP54	
Weight, approx.	g	63
<i>Bluetooth</i> [®] Low Energy 5.0		
- Frequency	MHz	2400–2480
- Transmission power	mW	≤ 1

A) Temperatures outside of this range may cause faults in the display.

The licence information for the product can be accessed at the following Internet address:
<http://www.bosch-ebike.com/licences>.

Declaration of Conformity

Robert Bosch GmbH, Bosch eBike Systems, hereby declares that the **Intuvia 100** radio communication unit complies with Directive 2014/53/EU. The full text of the EU Declaration of Conformity is available to view at the following website: <https://www.bosch-ebike.com/conformity>.

Robert Bosch GmbH, Bosch eBike Systems, hereby declares that the **Intuvia 100** radio communication unit complies with the Radio Equipment Regulations 2017 (SI 2917/1206). The full text of the UK Declaration of Conformity can be accessed at the following Internet address:
<https://www.bosch-ebike.com/conformity>.

UK
CA

Assembly

Inserting and removing the on-board computer (see figure A)

To **insert** the on-board computer, insert the lugs of the battery compartment (13) into the cradle (8) of the holder, and press the on-board computer gently down. To lock, turn the on-board computer clockwise until it engages.

To **remove** the on-board computer (9), turn it anticlockwise and remove the on-board computer from the cradle (8).

► **Remove the on-board computer when you park the eBike.**

Inserting the locking screw (see figure B)

The on-board computer can be secured in place to prevent it from being removed from the holder. The on-board computer must be in the holder for this. Undo the fastening screw (14) of the clamp with a hex key until the holder (7) can be moved. Turn the holder (7) until the bottom side of the on-board computer is accessible. Insert the locking screw (6) and bolt it with the on-board computer. Align the holder (7) correctly with the on-board computer and tighten the fastening screw (14) again with a hex key.

Please note: The locking screw is not designed to prevent theft.

Operation

Connection of the On-Board Computer with the eBike System (Pairing)

Your on-board computer is generally already connected with the eBike system. If this is not the case, proceed as follows:

- Install the **eBike Flow** app.
- Activate *Bluetooth*[®] on your smartphone and open the **eBike Flow** app.
- Briefly press the *Bluetooth*[®] button.
- The device identification is shown on the display.
- Select the required tool with the same identification in the **eBike Flow** app.

You can find further information at the following link:

<https://www.bosch-ebike.com/de/help-center/intuvia-100>.



Depending on the smartphone's operating system, the **eBike Flow** app can be downloaded free of charge from the Apple App Store and the Google Play store.

Use your smartphone to scan the code in order to download the **eBike Flow** app.

Switching the on-board computer on/off

Switch on the eBike system.

To **switch on** the on-board computer, gently move the eBike or tap the display.

The following options are available for **switching off** the on-board computer:

- Press the ON/OFF button on the operating unit to switch off the eBike system.
The on-board computer is also switched off.
- Remove the on-board computer from its holder.
The on-board computer switches off automatically after 60 seconds.

Power supply for the on-board computer

The on-board computer is provided with energy by the CR2450 coin cell.

Changing the non-rechargeable battery (see figure C)

When the non-rechargeable battery of the on-board computer is nearly drained, you're shown a corresponding message on the display. Open the battery compartment cover (2) with a slotted screwdriver (12), remove the used non-rechargeable battery and insert a new non-rechargeable battery of type CR2450. You can obtain the non-rechargeable batteries recommended by Bosch from your bicycle dealer.

When inserting the non-rechargeable battery, ensure that the rubber seal (10) is correctly positioned.

Seal the battery compartment and slide the on-board computer onto the holder.

Battery charge indicator

The on-board computer shows the state of charge of the eBike rechargeable battery in per cent. A notification is displayed once when the battery's state of charge falls below 30%, and again when it falls below 10%. The notification can be confirmed, or it simply disappears after 5 s.

Operation

The *Bluetooth*[®] (1) button has various functions. If the on-board computer was connected with an operating unit and has been removed from the holder, the displays can be switched within 60 s. To do so, briefly press the *Bluetooth*[®] (1) button.

Note: If you are not going to be using your eBike for several weeks, remove the on-board computer from its holder and set the on-board computer to storage mode. To do so, press the *Bluetooth*[®] (1) button for 8–11 s.

The reset button (5) serves to reset the on-board computer to factory settings and delete all connections.

The on-board computer can be operated and the indicators can be controlled via one of the depicted operating units. The meaning of the buttons on the operating units for the display indicators can be found in the following overview. Depending on how long it is pressed for, the select button has 2 functions.

LED Remote

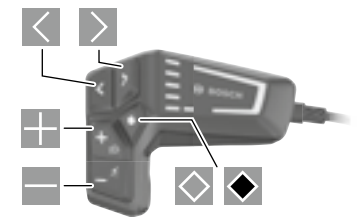

Mini Remote

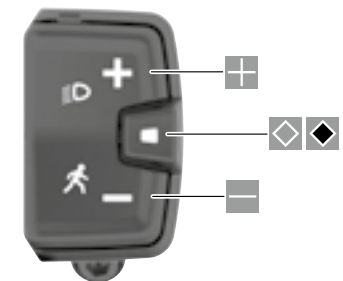

- Scroll right (only for LED Remote)
- ⊕ Increase assistance level
- ⊖ Decrease assistance level
- ⊠ Select button (press briefly)
- ⊠ Select button (press and hold > 1 s)

Please note: All screenshots showing the display and text on the following pages are from the approved software version. The display and/or text may change slightly following a software update.

Note: Depending on the lighting conditions, there is background lighting that is only activated by pressing a button. The lighting duration can be adjusted.

Displays and settings of the on-board computer

Speed and distance indicators

The speedometer always displays the current speed.



You can choose from the following functions in the function display (combination of text indicator and value indicator):

- **<Distance>**: Distance travelled since the last reset
- **<Riding time>**: Journey time since the last reset
- **<Time>**: Current time
- **<Range>**: Estimated range of the available battery charge (at constant conditions such as assistance level, route profile, etc.)
- **<Avg. Speed>**: Average speed achieved since the last reset
- **<Max. Speed>**: Maximum speed achieved since the last reset
- **<Total distance>**: Total distance travelled with the eBike (cannot be reset)

Note: The on-board computer automatically displays a gear change recommendation when riding the eBike. The display of the gear change recommendation is superimposed over the text display **(f)** of the on-board computer, and can be deactivated manually via the basic settings.

Switching Between Display Functions

 Press the  or  button until the required function is displayed.

 Press the  button until the required function is displayed.

Certain settings cannot be assumed on the on-board computer, but only in the **eBike Flow** app, e.g.:

- **<Wheel circum.>**
- **<Range reset>**
- **<Auto trip reset>**



In addition, you receive an overview of the operating hours and the installed components in the **eBike Flow** app.



Displaying/adjusting basic settings

Note: The settings menu cannot be called up while riding.

To get to the basic settings menu, press the  button on the operating unit until **<Settings>** appears in the text display.



Switching/Leaving Basic Settings



 Press the  or  button until the required basic setting is displayed.

 Press the  button until the required basic setting is displayed.

Note: The changed setting is automatically saved upon leaving the respective basic setting.

Changing Basic Settings

 To scroll down, briefly press the  button until the required value is displayed.

 To scroll down, press the  button > 1 s until the required value is displayed.



Note: Pressing and holding the relevant button switches automatically to the next value in the basic settings.

You can choose between the following basic settings:

- **<Language>**: You can select your preferred system language here.
- **<Units>**: Displaying the speed and distance in either kilometres or miles.
- **<Time>**: You can set the time here.
- **<Time format>**: Displaying the time in 12-hour or 24-hour format.
- **<Shift recommendation>**: You can choose whether or not to have a prompt displayed when it is recommended that you change gears.
- **<Backlight>**: You can set the duration of the background lighting here.
- **<Brightness>**: The brightness can be adjusted in steps of 5% from 5–100%.
- **<Settings reset>**: You can reset the settings by pressing and holding the select button here.
- **<Certifications>**
- **<Back>**: You can leave the settings menu with this function.

Leaving the Basic Settings Menu

You leave the basic settings menu automatically if you are inactive for 60 s or start riding the eBike, or by using the **<Back>** function.

 Briefly press the  button to leave the basic settings menu using the **<Back>** function.



Press the  button > 1 s to leave the basic settings menu using the **<Back>** function.

Please return Bosch eBike components that are no longer usable free of charge to an authorised bicycle dealer or to a recycling facility.

Subject to change without notice.

Maintenance and servicing

Maintenance and cleaning

Do not clean any of the components with pressurised water. Keep the screen of your on-board computer clean. Dirt can cause faulty brightness detection.

Clean your on-board computer using a soft cloth dampened only with water. Do not use cleaning products of any kind.

Have your eBike system checked by an expert at least once a year (including mechanical parts, up-to-dateness of system software).

In addition, the bicycle dealer may base the service date on the distance travelled and/or on a period of time. In this case, the on-board computer displays a message telling you when the service date is due each time it is switched on.

Please have your eBike serviced and repaired by an authorised bicycle dealer.

► **Have all repairs performed only by an authorised bike dealer.**

Note: If you are handing in your eBike to a bicycle dealer for maintenance, it is recommended that you temporarily deactivate the **<eBike Lock>** and **<eBike Alarm>** to prevent false alarms.

After-sales service and advice on using products

If you have any questions about the eBike system and its components, contact an authorised bicycle dealer.

For contact details of authorised bike dealerships, please visit www.bosch-ebike.com.

Transport

► **If you transport your eBike attached to the outside of your car, e.g. on a bike rack, remove the on-board computer and the eBike battery to avoid damaging them.**

Disposal



The drive unit, on-board computer incl. operating unit, battery, speed sensor, accessories and packaging should be disposed of in an environmentally correct manner.

Check that your personal data has been deleted from the device.

Do not dispose of eBikes and their components with household waste.



In accordance with Directive 2012/19/EU and Directive 2006/66/EC respectively, electronic devices that are no longer usable and defective/drained batteries must be collected separately and recycled in an environmentally friendly manner.



7.3 Purion 200

BRC3800



en Original operating instructions
fr Notice d'utilisation d'origine
es Instrucciones de servicio originales

This manual contains important safety, performance and service information. Read and understand it along with the information provided to you by your bicycle manufacturer before using the product, and keep it for reference.

Introduction

About Warnings

This manual contains many **DANGER**, **WARNING**, and **CAUTION** indicators concerning the consequences of failure to use, assemble, maintain, store, inspect and dispose of a Bosch-equipped eBike in a safe manner.

- The combination of the safety alert symbol and the word **DANGER** indicates a hazardous situation that, if not avoided, will result in death or serious injury.

- The combination of the safety alert symbol and the word **WARNING** indicates a hazardous situation that, if not avoided, could result in death or serious injury.
- The combination of the safety alert symbol and the word **CAUTION** indicates a hazardous situation that, if not avoided, could result in minor or moderate injury.

General Warnings



Read all safety warnings and all instructions. Failure to follow the warnings and instructions may result in death or serious injury.

Save all safety warnings and instructions for future reference.

The term **eBike battery** used in these operating instructions refers to all original Bosch eBike batteries from the system generation **the smart system**.

- ▶ **Read ALL accompanying manuals before riding the bike for the first time.** Your Bosch Drive System comes with additional manuals and documents provided by the manufacturer of the bicycle and other components. Failure to read and understand safety information can result in death or serious injury.

WARNING

- ▶ **This manual contains important safety, performance and service information.** Read it before you take the first ride on your new bicycle, and keep it for reference. The manual can also be found online at www.bosch-ebike.com.
- ▶ **This manual is intended to be read together with the separate user manual provided with your bicycle.** Be sure to read all provided documents including labels on the product before your first ride.

- ▶ **Take responsibility for your own SAFETY.** If you have any questions or do not understand something, consult with your dealer or the bicycle or component manufacturer.
- ▶ **Some eBike accessories may present a choking hazard to small children.** Keep these accessories away from children.

CAUTION

- ▶ **The Bosch Drive System adds weight to your bicycle which you may not be used to lift.** Avoid injury, use proper lifting techniques.



Using your Manual

In addition to the functions outlined here, changes to software relating to troubleshooting and functional modifications may be introduced at any time.

Graphics

The bicycle shown in this manual may differ slightly from your bicycle, but will be similar enough to help you understand our instructions.

RIGHT-HAND and LEFT-HAND sides are determined by facing in the direction the bicycle will travel when going forward. When you see a broken line (-----), the item referred to is hidden from view.

Operating your Bosch Drive System

Safety instructions



Read all the safety and general instructions. Failure to follow the warnings and instructions may result in electric shock,

fire and/or serious injury.

Save all safety warnings and instructions for future reference.

The term **eBike battery** used in these operating instructions refers to all original Bosch eBike batteries from the system generation **the smart system**.

The terms **drive** and **drive unit** used in these operating instructions refer to all original Bosch drive units from the system generation **the smart system**.

- ▶ **Read and observe the safety warnings and instructions in all operating instructions of the eBike system and your eBike.**
- ▶ **Do not attempt to fix display or remote control while riding!**
- ▶ **Do not allow yourself to be distracted by the control unit's display.** If you do not concentrate exclusively on the traffic around you, you risk being involved in an accident. If you want to change settings on your control unit, beyond just changing the assistance level, stop cycling to do so.
- ▶ **Set the display brightness such that you can adequately see important information like speed or warning symbols.** An incorrectly set display brightness can result in dangerous situations.
- ▶ **Do not use the control unit as a handle.** If you lift up the eBike by the control unit, you may cause irreparable damage to the control unit.
- ▶ **The push assistance function must only be used when pushing the eBike.** There is a risk of injury if the wheels of the eBike are not in contact with the ground while using the push assistance.
- ▶ **When the push assistance is activated, the pedals may turn at the same time.** When the push assistance function is activated, make sure that there

is enough space between your legs and the turning pedals to avoid the risk of injury.

- ▶ **When using the push assistance, ensure that you can always control the eBike and hold it securely.** The push assistance can be suspended under certain conditions (e.g. obstacle on the pedal or accidentally slipping off the button of the operating unit). The eBike can suddenly move backwards towards you or start to tip. This poses a particular risk for the user if there is an additional load. When using the push assistance on the eBike, do not place the eBike in situations in which you cannot hold the eBike by yourself.
- ▶ **Do not activate push assistance function while riding on the bike.** Only use push assistance function when pushing the eBike.
- ▶ **Do not stand your eBike upside down on its handlebars and saddle if the operating unit or its holder protrude from the handlebars.** This may irreparably damage the operating unit or the holder.
- ▶ **Do not connect a charger to the eBike battery if the display of the operating unit or the on-board computer indicates that a critical error has occurred.** This may result in damage to your eBike battery. The eBike battery may catch fire, thereby resulting in serious burns and other injuries.
- ▶ **The control unit features a wireless interface. Local operating restrictions, e.g. in airplanes or hospitals, must be adhered to.**
- ▶ **Caution!** When using the operating unit with *Bluetooth*[®], this may cause interference that affects other devices and systems, airplanes and medical devices (e.g. pacemakers, hearing aids). Similarly, the possibility that this may cause damage to humans and animals in the immediate vicinity cannot be completely excluded. Do not use the operating unit with *Bluetooth*[®] in the vicinity of medical de-



vices, gas stations, chemical plants, areas with a potentially explosive atmosphere or on blast sites. Do not use the operating unit with *Bluetooth*® in airplanes. Avoid using the device in close proximity to your body over an extended period of time.

- ▶ The *Bluetooth*® wordmark and its logos are the registered trademarks and property of Bluetooth SIG, Inc. Any use of this wordmark/these logos by Robert Bosch GmbH, Bosch eBike Systems is under license.
- ▶ **Accessing other apps, reading pop up messages/other content, or otherwise using your mobile device while operating an eBike may be distracting. Distracted driving is a serious safety concern and can lead to accidents causing serious injury or death. In order to prevent distracted driving, most mobile devices come equipped with a “Do Not Disturb” mode. The “Do Not Disturb” mode should be used while operating an eBike.** Please consult your device-specific instructions for more information. You, as the eBike operator, are fully responsible for ensuring that you pay attention to road conditions and comply with traffic laws at all times.
- ▶ **Do not enter information or make selections while riding.** Interacting with the display unit while riding can lead to accidents causing serious injury or death. You must observe road and traffic conditions, and comply with traffic laws at all times.
- ▶ Please note that certain State or local laws may require that class III eBikes must be equipped with a functioning speedometer that displays speed in miles per hour. Riders must be aware of any and all applicable rules and regulations related to the operation or use of class III eBikes in any applicable jurisdictions before operating or otherwise using this product.
- ▶ **Observe all national regulations which set out the approved use of eBikes.**

Safety warnings for charging the battery inside the remote control

- ▶ **Only charge the remote control with USB power source (5 V, 600 mA max) and USB cable rated at least 600 mA.** Using USB power source or USB cable not appropriately rated for the application may result in fire, explosion or personal injury.
- ▶ **Charge the remote control in temperatures above +32 degrees F (0 degrees C) and below +104 degrees F (40 degrees C). Store remote control in locations where temperatures will not exceed 104 degrees F (40 degrees C).** This is important to prevent serious damage to the battery in the remote control.
- ▶ **Do not expose remote control to fire or excessive temperature.** Exposure to fire or temperature above 212 °F (100 °C) may cause explosion.
- ▶ **Do not recharge the remote control (via USB port) in damp or wet environment.** Water entering remote control may result in electric shock or fire.
- ▶ **Never submerge remote control in fluid of any kind or allow fluid to enter them.** Corrosive or conductive fluid (such as seawater or industrial chemical or bleach containing products, etc.) can cause short circuit which may result in fire, personal injury and property damage.
- ▶ **Battery leakage may occur under extreme usage or temperature conditions. Avoid contact with skin and eyes.** The battery liquid is caustic and could cause chemical burns to tissues. If liquid comes in contact with skin, wash quickly with soap and water. If the liquid contacts your eyes, immediately flush eyes with water for a minimum of 15 minutes and seek medical attention.
- ▶ **Before each use, check the remote control, cable and plug.** If damage is detected, do not use the remote control. Damaged remote control, charging cables and plugs increase the risk of a fire, explosion and personal injury.

- ▶ **Do not disassemble remote control.** No user-serviceable part inside. Incorrect reassembly or damage may result in fire or explosion.

NOTICE: This device complies with part 15 of the FCC Rules. Operation is subject to the following two conditions:

1. This device must not cause harmful interference, and
2. this device must accept any interference received, including interference that may cause undesired operation.

NOTICE: Changes or modifications made to this equipment not expressly approved by the Robert Bosch GmbH may void the FCC authorization to operate this equipment.

NOTE: This equipment has been tested and found to comply with the limits for a Class B digital device, pursuant to Part 15 of the FCC Rules. These limits are designed to provide reasonable protection against harmful interference in a residential installation. This equipment generates, uses and can radiate radio frequency energy and, if not installed and used in accordance with the instructions, may cause harmful interference to radio communications. However, there is no guarantee that interference will not occur in a particular installation. If this equipment does cause harmful interference to radio or television reception, which can be determined by turning the equipment off and on, the user is encouraged to try to correct the interference by one or more of the following measures:

- Reorient or relocate the receiving antenna.
- Increase the separation between the equipment and receiver.
- Connect the equipment into an outlet on a circuit different from that to which the receiver is connected.
- Consult the dealer or an experienced radio/TV technician for help.

Radiofrequency radiation exposure Information:

The radiated output power of the device is far below the FCC radio frequency exposure limits. Neverthe-

less, the device shall be used in such a manner that the potential for human contact during normal operation is minimized.

This equipment complies with FCC radiation exposure limits set forth for an uncontrolled environment. This transmitter must not be co-located or operating in conjunction with any other antenna or transmitter.

ISED Notice (Canada)

This device contains licence-exempt transmitter(s)/receiver(s) that comply with Innovation, Science and Economic Development Canada's licence-exempt RSS(s). Operation is subject to the following two conditions:

1. this device may not cause interference, and
2. this device must accept any interference, including interference that may cause undesired operation of the device.

This equipment complies with Canada radiation exposure limits set forth for an uncontrolled environment. This transmitter must not be co-located or operating in conjunction with any other antenna or transmitter.

Privacy notice

When connecting the eBike to the **Bosch Diagnostic-Tool 3** or when exchanging eBike components, technical information about your eBike (e.g. manufacturer, model, bike ID, configuration data) as well as regarding the use of the eBike (e.g. total travel time, energy consumption, temperature) is transmitted to Bosch eBike Systems (Robert Bosch GmbH) for processing your request, in service cases and for the purposes of product improvement. More information on data processing can be found at www.bosch-ebike.com/privacy-full.



Product Description and Specifications

Product Features

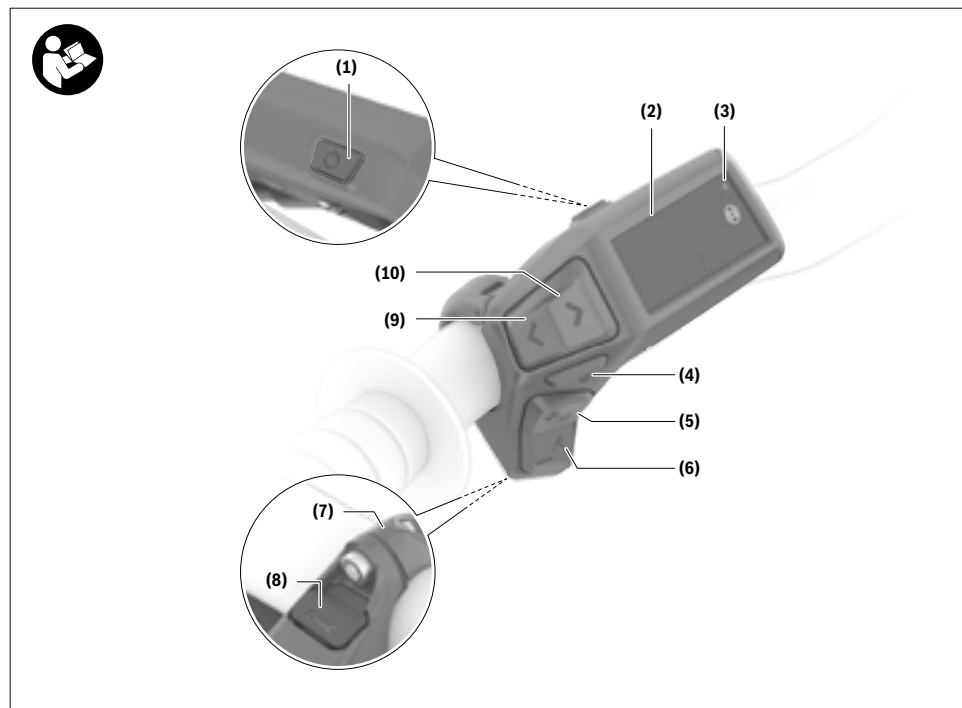

All illustrations of bike parts except for the drive unit, on-board computer including operating unit, speed sensor and the corresponding holders are schematic and may differ on your eBike.

- (1) On/off button
- (2) Display
- (3) Ambient light sensor
- (4) Select button
- (5) Button for increasing assistance +/- bicycle lights
- (6) Button for decreasing assistance -/ push assistance
- (7) Holder
- (8) Diagnostics connection (for servicing purposes only)
- (9) Button to reduce brightness/go back
- (10) Button to increase brightness/go forward

Intended Use

The **Purion 200** control unit is designed for controlling an eBike and, as an option, for controlling an additional on-board computer from the system generation **the smart system**. If you use your smartphone as an on-board computer, you can use the **Purion 200** control unit to change the assistance level in the **eBike Flow** app.

In order to be able to use the control unit to its fullest extent, a compatible smartphone with the **eBike Flow** app is required.

You can connect the **Purion 200** operating unit with your smartphone via **Bluetooth®**.

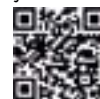

Depending on the operating system of the smartphone, the **eBike Flow** app can be downloaded free of charge from the Apple App Store or Google Play Store.

Scan the code with your smartphone to download the **eBike Flow** app.

Technical Data

Control unit	Purion 200	
Product code		BRC3800
Max. charging current of USB port ^{A)}	mA	600
USB port charging voltage ^{A)}	V	5
USB charging cable ^{B)}		USB Type-C ^{C)}
Charging temperature	°F	32 to 113
Operating temperature	°F	23 to 104
Storage temperature	°F	50 to 104
Diagnostic interface		USB Type-C ^{C)}
Internal lithium-ion battery	V	3.7
	mAh	75
Protection rating		IP55
Dimensions (without fastening)	in	3.3 × 2.1 × 2.4
	lb	0.11
Bluetooth® Low Energy 5.0		
- Frequency	MHz	2400–2480

Control unit Purion 200

- Transmission power mW 1

A) Information for charging the **Purion 200** operating unit; external devices cannot be charged.

B) Not included with the product as standard

C) USB Type-C® and USB-C® are trademarks of USB Implementers Forum.

The license information for the product is available at the following Internet address: www.bosch-ebike.com/licences

Certification information

FCC and IC ID (e-labels) can be found in the status screen under **<Settings>** → **<Information>** → **<Certificates>**. Scroll through all e-labels by briefly pressing the scroll on button **(10)**.

Note: If you wish to access information from the e-label of **Purion 200**, you may first have to remove any additional on-board computer or, if using a smartphone, close the ride screen in the **eBike Flow** app.



Operation

Requirements

The eBike can then only be switched on when the following requirements are met:

- A sufficiently charged eBike battery is inserted (see operating instructions for the eBike battery of the system generation **the smart system**).
- The speed sensor is connected properly (see operating instructions for the drive unit of the system generation **the smart system**).

Before setting off, make sure that you can easily reach the buttons on the operating unit. It is recommended to align the plus/minus buttons level so that it is almost perpendicular to the ground.

Control unit power supply

If a sufficiently charged eBike battery is inserted into the eBike and the eBike is switched on, the internal battery of the operating unit is powered and charged. If the state of charge of the internal battery of the operating unit is very low, you can charge it via the diagnostics connection **(8)** with a USB Type-C® cable using a power bank or another suitable power source (charging voltage **5 V**; charging current max. **600 mA**).

Always close the flap of the diagnostics connection **(8)** so that no dust or moisture can enter.

Switching the eBike on/off

To **switch on** the eBike, briefly press the on/off button **(1)**. The eBike is ready to ride once the start-up animation is complete.

The display brightness is controlled by the ambient light sensor **(3)**. Therefore, do not cover the ambient light sensor **(3)**.

The drive is activated as soon as you start pedaling (except at assistance level **OFF**). The drive output depends on the settings of the assistance level.

As soon as you stop pedaling when in normal operation, or as soon as you have reached a speed of **20/28 mph**, the drive switches off the assistance. The drive is automatically re-activated as soon you

start pedaling again and the speed is below **20/28 mph**.

To **switch off** the eBike, press the on/off button **(1)** briefly (< 3 s).

If no power is requested from the drive for approx. **10 minutes** (e.g. due to the eBike being stationary) and no button is pressed, the eBike switches off automatically.

Quick menu

Selected settings are displayed on the quick menu. These settings can also be changed while riding. The quick menu can be accessed with a long press (> 1 s) of the select button **(4)**.

It cannot be accessed from the status page.

The following settings can be changed via the quick menu:

- **<Reset trip>**
All data on the distance traveled so far is set to zero.
- **<eShift>** (optional)

The settings are dependent on the respective gear-shifting.

Note: Depending on the configuration of your eBike, additional functions may be available.

Displays

Note: All interface displays and texts on the following pages correspond to the release status of the software. The interface displays and texts may change slightly following a software update.

If you did not select another page before the last time you switched off, you will be shown this page.

Start page



- (a)** State of charge of eBike battery
- (b)** Assistance level
- (c)** Unit of speed indicator
- (d)** Your performance
- (e)** Speed
- (f)** Drive power

You can view other screens by pressing the **(4)** or **(5)** buttons.

The following additional screens are available for you to view:

- Status screen: The status of the connected devices is shown here.
- Distances screen
- Rides screen
- Range screen
- eBike battery screen
- Power screen
- Cadence screen
- Total distances screen
- ABS screen (optional)

Selecting the assistance level

You can set how much the eBike drive assists you while pedaling by pressing the increase assistance level **+** **(5)** and reduce assistance level **-** **(6)** buttons on the control unit. The assistance level can be changed at any time, even while cycling, and is displayed in color.

Level	Notes
OFF	The drive support is switched off. The eBike can just be moved by pedaling, as with a normal bicycle.
ECO	Effective support with maximum efficiency, for maximum range
TOUR	Steady support, long range for touring
TOUR+	Dynamic support for normal riding and biking sports
eMTB	Optimal support whatever the terrain, rapid acceleration when starting from a standstill, improved dynamics and top performance
SPORT	Powerful assistance, for mountain biking and for cycling in urban traffic
TURBO	Maximum support even at a high cadence, for sport cycling
AUTO	The assistance is adapted dynamically to the riding situation.
RACE	Maximum support on the eMTB race course; very direct response behavior and maximum "extended boost" for the best possible performance in competitive situations
CARGO	Steady, powerful support, to be able to transport heavy weights
SPRINT	Dynamic support depending on the cadence – for sport-based eGravel and eRoad riding with quick sprints and frequent ascents

Note: The available modes are dependent on the respective drive unit.

The designations and configuration of the assistance levels can be preconfigured by the manufacturer and selected by the bicycle retailer.

Adjusting the assistance level

The assistance levels can be adjusted within certain parameters using the **eBike Flow** app. You therefore have the option of adjusting your eBike to your personal requirements.

Creating a mode that is totally your own is not possible. You can only adjust the modes that have been enabled on your system by the manufacturer or the dealer. This may even be fewer than 4 modes.

It may also be the case that a mode cannot be adjusted due to restrictions in your country.

The following parameters are available to you for adjustment:

- Support in relation to the basic value of the mode (within the legal specifications)
- Response behavior of the drive
- Throttling down speed (within the legal specifications)
- Maximum torque (within the framework of the drive limits)

Note: Please ensure that your changed mode retains the position, name and color on all on-board computers and operating elements.

Interaction of the drive unit with the gear-shifting

You should shift through gears on an eBike in the same manner as when using a normal bicycle (observe the operating instructions of your eBike with regard to this point).

Irrespective of the type of gear shifting, it is advisable that you briefly reduce the pressure on the pedals when changing gear. This will aid gear shifting and reduce wear on the powertrain.

By selecting the correct gear, you can increase your speed and range while applying the same amount of force.

Therefore, follow the gear-shifting recommendations that are displayed to you on your on-board computer.

Switching bike lights on/off

Before starting each journey, check that your bike lights are working correctly.

To **switch on** the bicycle lights, press the bicycle lights button **(5)** for more than 1 s.

Switching the push assistance on/off

The push assistance aids you when pushing your eBike. The maximum speed of the push assistance is **3.7 mph**. The manufacturer's default setting can be lower and may need to be adjusted by the bicycle retailer.

► **The push assistance function must only be used when pushing the eBike.** There is a risk of injury if the wheels of the eBike are not in contact with the ground while using the push assistance.

► **If the selected gear is too high, the drive unit may not be able to move the eBike or activate the roll-away lock.**

To **start** walk assistance, press the walk assistance **(6)** button for more than 1 s, keep it pressed and follow the instructions on the display.

To **activate** push assistance, one of the following actions must occur within the next 10 s:

- Push the eBike forward.
- Push the eBike backward.
- Perform a sideways tilting movement with the eBike.

After activation, the drive begins to push and the indicator on the display changes.

If you release the push assistance button **(6)**, push assistance is paused. You can reactivate push assistance within 10 s by pressing the push assistance button **(6)**.

If you do not reactivate push assistance within 10 s, push assistance automatically switches off.

Push assistance is always ended if:

- the rear wheel jams;
- the bicycle cannot move over ridges;

- a body part is blocking the bicycle crank;
- an obstacle continues to turn the crank;
- you start pedaling;
- the "Increase assistance" +/bicycle lights button **(5)** or on/off button **(1)** is pressed.

Push assistance has a roll-away lock, which means that even after successfully using push assistance, the drive actively brakes backward rolling for a few seconds and you cannot push the eBike backward or can only do so with difficulty.

The roll-away lock can be immediately deactivated by pressing the "Increase assistance" +/bicycle lights button **(5)**.

The push assistance function is subject to local regulations; the way it works may therefore differ from the description above. It can also be deactivated.

ABS – Anti-lock braking system (optional)

If the eBike is fitted with a Bosch eBike ABS from the system generation **the smart system**, the ABS symbol lights up when the eBike system starts.

After moving off, the ABS internally checks its functionality and the ABS symbol goes off.

In the event of an error, the ABS symbol lights up and a message appears on the display. This means that the ABS is inactive. You can press the select button **(4)** to acknowledge the error and the ABS error message disappears. The ABS symbol appears in the statusbar to notify you that the ABS is still switched off.

For details on the ABS and how it works, please refer to the ABS operating instructions.



Establishing a smartphone connection

In order to be able to use the following eBike functions, a smartphone with the **eBike Flow** app is required.

Connection to the app occurs via a *Bluetooth*® connection.

Switch on the eBike without maneuvering it.

Begin *Bluetooth*® pairing by long pressing (> 3 s) the on/off button **(1)**. When the status of the pairing process is displayed, release the on/off button **(1)**.

Confirm the connection request in the app.

Activity tracking

In order to record activities, it is necessary to register and log into the **eBike Flow** app.

To record activities, you must consent to the storage of your location data in the app. Without this, your activities cannot be recorded in the app. For location data to be recorded, you must be logged in as the user.

eBike Lock

<eBike Lock> can be activated for all users via the **eBike Flow** app. A key to unlock the eBike is saved on the smartphone for this purpose.

<eBike Lock> is automatically active in the following cases:

- When switching off the eBike via the operating unit
- When automatically switching off the eBike

The eBike is unlocked when the eBike is switched on and the smartphone is connected with the eBike via *Bluetooth*®.

<eBike Lock> is connected to your **user account**.

Should you lose your smartphone, you can log in via another smartphone using the **eBike Flow** app, and unlock your user account and the eBike.

Warning! If you select a setting in the app that leads to disadvantages for the **<eBike Lock>** (e.g. deletion of your eBike or user account), then you will first be shown warning messages. **Please read through these thoroughly and adhere to the warnings that**

are issued (e.g. before deleting your eBike or user account).

In order to be able to set up the **<eBike Lock>**, the following conditions must be fulfilled:

- The **eBike Flow** app has been installed.
- A user account has been created.
- No update is currently being carried out on the eBike.
- The eBike is connected to the smartphone via *Bluetooth*®.
- The eBike is stationary.
- The smartphone is connected to the Internet.
- The eBike battery is sufficiently charged, and the charging cable is not connected.

You can set up **<eBike Lock>** in the **eBike Flow** app under the **<Settings>** menu item.

You can deactivate the support of your drive unit with immediate effect by switching on **<eBike Lock>** in the **eBike Flow** app. Deactivation can only be canceled if your smartphone is nearby when switching on the eBike. Your smartphone must have *Bluetooth*® switched on for this, and the **eBike Flow** app must be active in the background. The **eBike Flow** app does not have to be opened. If **<eBike Lock>** is activated, you can also use your eBike without support from the drive unit.

Compatibility

<eBike Lock> is compatible with these Bosch eBike product lines from the system generation **the smart system**:

Drive unit	Product line
BDU374x	Performance Line CX
BDU33xx	Performance Line Active Line Active Line Plus
BDU31xx	Performance Line SX

How it works

In conjunction with **<eBike Lock>**, the smartphone works in a similar way to a key for the drive unit.

The **<eBike Lock>** is activated by switching off the eBike. As long as the **<eBike Lock>** is active after the function is switched on, this will be indicated by a padlock symbol on the **Purion 200** control unit.

Note: **<eBike Lock>** alone does not provide adequate theft protection; it is simply a supplement to a mechanical lock. **<eBike Lock>** does not provide any form of mechanical lock for the eBike. Only the assistance from the drive unit is deactivated. As long as the smartphone is connected with the eBike via *Bluetooth*®, the drive unit is unlocked.

If you wish to give other users temporary or permanent access to your eBike or you want to take your eBike to a service, you will need to deactivate the <eBike Lock> in the eBike Flow app in the <Settings> menu item. If you wish to sell your eBike, you will also need to delete the eBike from your user account in the **eBike Flow** app in the **<Settings>** menu item.

When the eBike is switched off, the drive unit will emit a "Lock" sound (i.e. an audio signal that is played **once**) to indicate that the assistance from the drive unit is switched off.

Note: The audio signal will only be played if the eBike is switched on.

When the eBike is switched on, the drive unit will emit two "Unlock" sounds (i.e. an audio signal that is played **twice**) to indicate that the assistance from the drive unit is enabled again.

The "Lock" sound helps you to recognize whether **<eBike Lock>** is activated on your eBike. The audio signal is activated by default, but it can be deactivated in the **eBike Flow** app in the **<Settings>** menu item by selecting the lock symbol under your eBike.

Note: If you are no longer able to set up or switch off **<eBike Lock>**, please contact your bicycle dealer.

Replacing eBike components and <eBike Lock>

Replacing the smartphone

1. Install the **eBike Flow** app on the new smartphone.

2. Log in using **the same** account with which you activated **<eBike Lock>**.

3. **<eBike Lock>** is displayed as set up in the **eBike Flow** app.

Replacing the drive unit

1. **<eBike Lock>** is displayed as deactivated in the **eBike Flow** app.
2. Activate **<eBike Lock>** by pushing the **<eBike Lock>** control unit to the right.
3. If you are handing in your eBike to a bicycle dealer for maintenance, it is recommended that you temporarily deactivate **<eBike Lock>**.

If you have activated the **<eBike Alarm>**, you will be able to see this on the **Purion 200**.

More information about this can be found in the **eBike Flow** app or in the Help Center on the website www.bosch-ebike.com/en/help-center.

Software updates

Software updates must be started manually in the **eBike Flow** app.

Software updates are transferred from the app to the control unit in the background as soon as it is connected to the app. During the software update, keep watching the display on the control unit **Purion 200**. The eBike is then restarted.

You can control the software updates via the **eBike Flow** app.



Troubleshooting

The error messages are displayed in a pop-up on the **Purion 200** control unit.

The operating unit shows whether critical errors or less critical errors occur on the eBike.

The error messages generated by the eBike can be read via the **eBike Flow** app or by your bicycle retailer.

Via a link in the **eBike Flow** app, information about the error and support for rectifying the error can be displayed.

Less critical errors

Errors are acknowledged by pressing the select button (4).

You can use the following table to rectify the errors yourself if necessary. Otherwise, please contact your bicycle retailer.

Number	Troubleshooting
523005	The indicated error numbers show that there is interference when the sensors detect the magnetic field. See whether you have lost the magnet while riding.
514001	
514002	
514003	If you are using a magnet sensor, check that the sensor and magnet have been properly installed. Make sure too that the cable to the sensor is not damaged.
514006	If you are using a rim magnet, make sure that you do not have any magnetic field interference in the vicinity of the drive unit.

Critical errors

If a critical error occurs, follow the handling instructions on the following table.

Number	Handling instructions
660002	Please do not charge or use your battery any further. Please contact your specialist retailer.
6A0004	Remove the PowerMore battery and restart your eBike.

Number	Handling instructions
	If the problem persists, please contact your specialist retailer.
890000	<ul style="list-style-type: none"> – Acknowledge the error code. – Restart the eBike system. If the problem persists: <ul style="list-style-type: none"> – Acknowledge the error code. – Perform the software update. – Restart the eBike system. If the problem persists: <ul style="list-style-type: none"> – Please contact a Bosch eBike systems specialist retailer.

Maintenance and Service

Maintenance/cleaning

⚠ WARNING

- ▶ **Do not open any of the components. Service should only be carried out at an authorized Bosch eBike dealer.** Failure to follow above warning can cause death or serious injury. Refer to your bicycle manual or component manual for all non-Bosch drive system components.
- ▶ **Do not paint any components of the Bosch drive system as they may cause premature failure of the component.**
- ▶ **Do not submerge your eBike components in water, or wash with pressurized hose.** Your Bosch drive unit is designed to be water tight to rain water or non-pressure hose washing.

Do not clean any of the components with pressurized water.

Keep the display of your control unit clean. Dirt can cause faulty brightness detection.

Clean your control unit using a soft cloth dampened only with water. Do not use cleaning products of any kind.

Have your eBike checked by an expert at least once a year (including mechanical parts, up-to-dateness of system software).

The bike retailer can also schedule the service based on a mileage and/or a time period. In this case, the control unit displays a message telling you when the service date is due each time it is switched on.

Please have your eBike serviced and repaired by an authorized bicycle dealer.

▶ **Only have repairs performed by a certified bicycle dealer.**

Note: If you hand over your eBike to a bicycle dealer for maintenance, it is recommended to temporarily deactivate **<eBike Lock>** and **<eBike Alarm>** to avoid a false alarm.

After-sales service and advice on using products

If you have any questions about the eBike and its components, contact an authorized bicycle retailer.

For contact details of authorized bike dealerships, please visit www.bosch-ebike.com.

Please contact an authorized bicycle dealer if the eBike battery is no longer working.

Battery Recycling Program



The drive unit, on-board computer incl. operating unit, eBike battery, speed sensor, accessories and packaging should be disposed of in an environmentally correct manner.



You may recycle your Bosch battery pack by calling 1.800.822.8837.

Do not dispose of eBikes and their components with household waste.



7.4 LED Remote

BRC3600

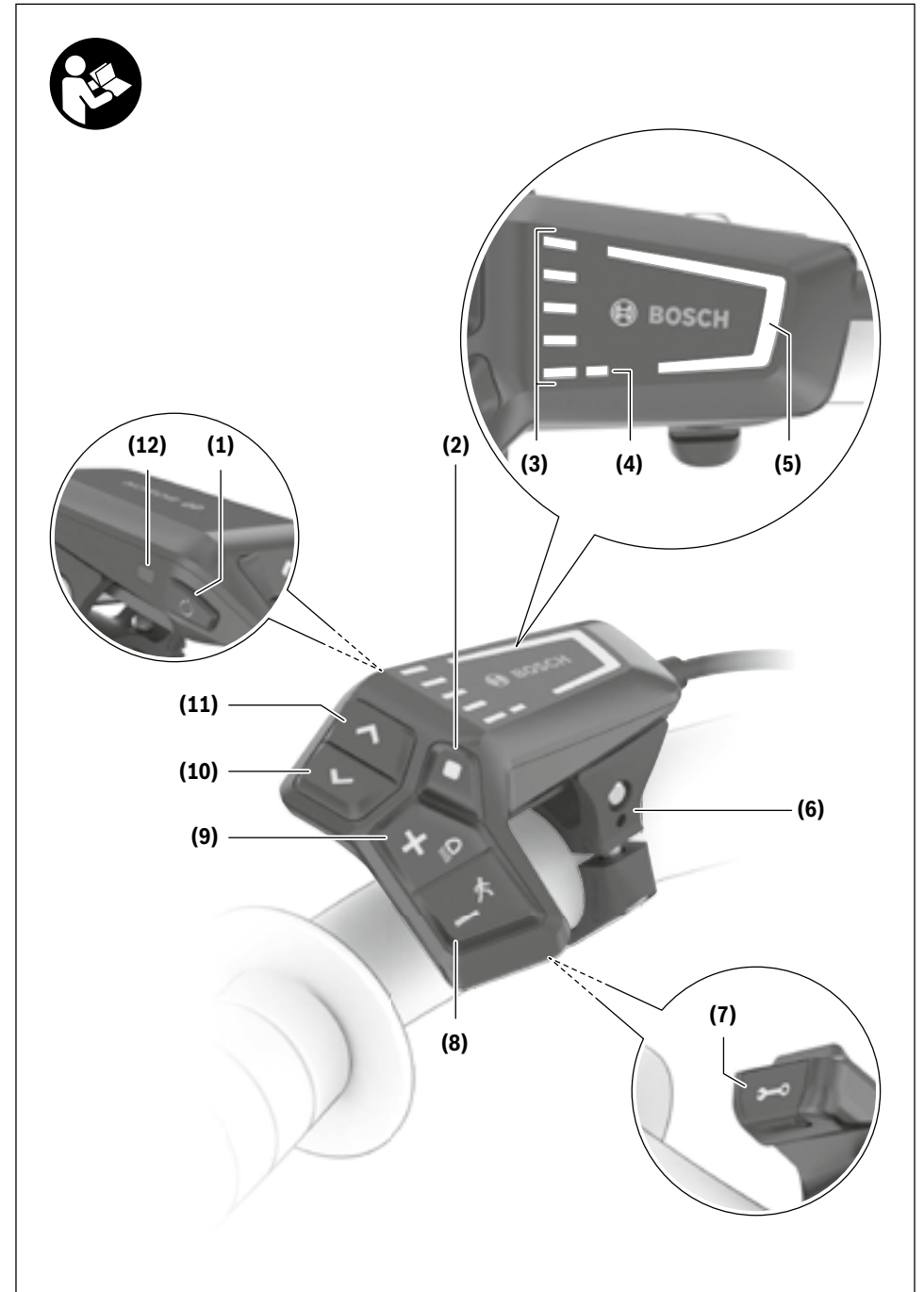

Safety instructions



Read all the safety information and instructions. Failure to observe the safety information and follow instructions may result in electric shock, fire and/or serious injury.

Save all safety warnings and instructions for future reference.

The term **battery** is used in these instructions to mean all original Bosch eBike rechargeable battery packs.

- ▶ **Read and observe the safety warnings and directions contained in all the eBike system operating instructions and in the operating instructions of your eBike.**
- ▶ **Do not attempt to secure the display or operating unit while riding.**
- ▶ **The push assistance function must only be used when pushing the eBike.** There is a risk of injury if the wheels of the eBike are not in contact with the ground while using the push assistance.
- ▶ **When the push assistance is activated, the pedals may turn at the same time.** When the push assistance function is activated, make sure that there is enough space between your legs and the turning pedals to avoid the risk of injury.
- ▶ **When using the walk assistance, make sure that you can control the eBike and that you can hold it securely at all times.** Under certain circumstances, the walk assistance may stop (e.g. if the pedals hit an obstacle or if you accidentally let go of the button on the operating unit). The eBike may suddenly move backwards onto you or tip up. This presents a risk for the user particularly if there is additional load on the eBike. When using the walk assistance, do not bring the eBike into situations in which you cannot hold the eBike using your own strength.
- ▶ **Do not stand your bicycle upside down on its handlebars and saddle if the operating unit or its holder protrude from the handlebars.** This may irreparably damage the operating unit or the holder.
- ▶ **Do not connect a charger to the eBike system if the eBike system displays a critical error.** This may result in damage to your battery. The battery may catch fire, thereby resulting in serious burns and other injuries.
- ▶ **The operating unit features a wireless interface. Local operating restrictions, e.g. in aeroplanes or hospitals, must be observed.**
- ▶ **Caution!** When using the operating unit with *Bluetooth*®, this may cause interference that affects other devices and systems, aeroplanes and medical devices (e.g. pace-makers, hearing aids). Likewise, injury to people and animals in the immediate vicinity cannot be excluded entirely. Do not use the operating unit with *Bluetooth*® in the vicinity of medical devices, petrol stations, chemical plants, areas with a potentially explosive atmosphere or on blast sites. Do not use the operating unit with *Bluetooth*® in aeroplanes. Avoid operation near your body for extended periods.

- ▶ The *Bluetooth*® word mark and logos are registered trademarks owned by Bluetooth SIG, Inc. and any use of such marks by Bosch eBike Systems is under licence.
- ▶ **Observe all national regulations which set out the approved use of eBikes.**

Privacy notice

When you connect the eBike to the **Bosch DiagnosticTool 3**, data about Bosch drive unit (e.g. energy consumption, temperature, etc.) is transferred to Bosch eBike Systems (Robert Bosch GmbH) for the purposes of product improvement. You can find more information about this on the Bosch eBike website at www.bosch-ebike.com.

Product description and specifications

Intended use

The **LED Remote** operating unit is designed to control a Bosch eBike system and control an on-board computer. You can also use it to change the assistance level in the **eBike Flow** app.

So as to be able to use the operating unit fully, a compatible smartphone with the **eBike Flow** app is required.

The **eBike Flow** app can be accessed via *Bluetooth*®.



Depending on the smartphone's operating system, the **eBike Flow** app can be downloaded free of charge from the Apple App Store and the Google Play store.

Use your smartphone to scan the code in order to download the **eBike Flow** app.

Product features

The numbering of the components shown refers to the illustrations on the graphics pages at the beginning of the manual.

All illustrations of bike parts except for the drive unit, on-board computer (including operating unit), speed sensor and the corresponding holders are a schematic representation and may differ on your eBike.

- (1) On/off button
- (2) Select button
- (3) LEDs for battery charge indicator
- (4) ABS LED (optional)
- (5) Assistance level LED
- (6) Holder
- (7) Diagnostics connection (for servicing purposes only)
- (8) Button for decreasing support level -/ walk assistance
- (9) Button for increasing support level +/ bike lights

- (10) Button to reduce brightness/ go back
- (11) Button to increase brightness/ go forward
- (12) Ambient light sensor

Technical data

Operating unit	LED Remote	
Product code		BRC3600
Max. charging current of USB port ^{A)}	mA	600
USB port charging voltage ^{A)}	V	5
USB charging cable ^{B)}		USB Type-C ^{C)}
Charging temperature	°C	0 to +45
Operating temperature	°C	-5 to +40
Storage temperature	°C	+10 to +40
Diagnostic interface		USB Type-C ^{C)}
Internal lithium-ion battery	V	3.7
	mAh	75
Protection rating		IP54
Dimensions (without fastening)	mm	74 × 53 × 35
Weight	g	30
<i>Bluetooth</i> ® Low Energy 5.0		
- Frequency	MHz	2400-2480
- Transmission power	mW	1

A) Specification for charging the **LED Remote**: external devices cannot be charged.

B) Not included as part of standard delivery

C) USB Type-C® and USB-C® are trademarks of USB Implementers Forum.

The licence information for the product can be accessed at the following Internet address: <https://www.bosch-ebike.com/licences>

Declaration of Conformity

Robert Bosch GmbH, Bosch eBike Systems, hereby declares that the **LED Remote** radio communication unit complies with Directive 2014/53/EU. The full text of the EU Declaration of Conformity is available to view at the following website: <https://www.bosch-ebike.com/conformity>.

Robert Bosch GmbH, Bosch eBike Systems, hereby declares that the **LED Remote** radio communication unit complies with the Radio Equipment Regulations 2017 (SI 2917/1206). The full text of the UK Declaration of Conformity can be accessed at the following Internet address: <https://www.bosch-ebike.com/conformity>.



Operation

Prerequisites

The eBike system can only be activated when the following requirements are met:

- A sufficiently charged battery is inserted (see battery operating instructions).
- The speed sensor is connected properly (see drive unit operating instructions).

Operating unit power supply

If a sufficiently charged eBike battery is inserted into the eBike and the eBike system is switched on, then the operating unit battery is powered and charged by the eBike battery.

If the state of charge of the internal battery is very low, you can charge the internal battery via the diagnostics connection (7) with a USB Type C® cable using a power bank or another suitable power source (charging voltage **5 V**; charging current max. **600 mA**).

Always close the flap of the diagnostics connection (7) so that no dust or moisture can enter.

Switching the eBike system on/off

To **switch on** the eBike system, briefly press the on/off button (1). After the starting animation, the state of charge of the battery is displayed in colour with the battery charge indicator (3) and the set assistance level with the (5) display. The eBike is ready to ride.

The display brightness is controlled by the ambient light sensor (12). Therefore, do not cover the ambient light sensor (12).

The drive is activated as soon as you start pedalling (except at assistance level **OFF**). The motor output depends on the settings of the assistance level.

As soon as you stop pedalling when in normal operation, or as soon as you have reached a speed of **25/45 km/h**, the eBike drive switches off the assistance. The drive is automatically reactivated as soon you start pedalling again and the speed is below **25/45 km/h**.

To **switch off** the eBike system, press the on/off button (1) briefly (< 3 s). The battery charge indicator (3) and the assistance level LED (5) go out.

If no power is drawn from the eBike drive for about **10 minutes** (e.g. because the eBike is not moving) and no button is pressed on the on-board computer or the control unit of the eBike, the eBike system will switch off automatically.

Battery charge indicator

The battery charge indicator (3) displays the eBike battery's state of charge. The state of charge of the eBike battery can also be checked on the LEDs of the battery itself.

In the (3) display, each ice-blue bar represents 20 % capacity and each white bar represents 10 % capacity. The top-most bar shows the maximum capacity.



Example: Four ice-blue bars and one white bar are displayed. The state of charge is between 81 % and 90 %. If capacity is low, both of the lower displays change colour:

Bar	Capacity
2 × orange	30 % to 21 %
1 × orange	20 % to 11 %
1 × red	10 % to reserve
1 × red flashing	Reserve to empty

If the eBike battery is being charged, the topmost bar on the battery charge indicator (3) flashes.

Setting the assistance level

You can set how much the eBike drive assists you while pedalling on the operating unit using the (8) and (9) buttons. The assistance level can be changed at any time, even while cycling, and is displayed in colour.

Level	Notes
OFF	Motor support is switched off. The eBike can just be moved by pedalling, as with a normal bicycle.
ECO	Effective support with maximum efficiency, for maximum range
TOUR	Steady support, long range for touring
TOUR+	Dynamic assistance for natural, sporty cycling
eMTB/SPORT	Optimal support whatever the terrain, rapid acceleration when starting from a standstill, improved dynamics and top performance
TURBO	Maximum support even at a high cadence, for sport cycling
AUTO	The support is dynamically adapted to the riding situation.
RACE	Maximum support on the eMTB racetrack; very direct response and maximum "Extended Boost" for the best possible performance in competitive situations
CARGO^{A)}	Steady, powerful support, so as to be able to safely transport heavy weights

A) The **CARGO** assistance level can have an additional description. The designations and configuration of the assistance levels can be preconfigured by the manufacturer and selected by the bicycle retailer.

Adapting the Assistance Level

The assistance level can be adapted within certain limits using the **eBike Flow** app. This gives you the option of adjusting your eBike to your personal requirements.

It is not possible to create a completely new mode. You can only adjust the modes that have been enabled by the manufacturer or dealer on your system. This may be fewer than 4 modes.

Due to technical limitations, you cannot adjust the **eMTB** and **TOUR+** modes. In addition, restrictions in your country may mean that it is not possible to adjust a particular mode.

The following parameters are available for making adjustments:

- Assistance in relation to the base value of the mode (within the legal requirements)
- Drive response
- Top limit speed (within the legal requirements)
- Maximum torque (within the limits of the drive)

The parameters are dependent on each other and influence each other. For example, it is not fundamentally possible to simultaneously set a low torque value and high assistance.

Note: Please ensure that your modified mode retains the position, name and colour on all on-board computers and controls.

Interaction between the eBike system and gear-shifting

The gear shifting should be used with an eBike drive in the same way as with a normal bicycle (observe the operating instructions of your eBike on this point).

Irrespective of the type of gear shifting, it is advisable that you briefly reduce the pressure on the pedals when changing gear. This will aid gear shifting and reduce wear on the powertrain.

By selecting the correct gear, you can increase your speed and range while applying the same amount of force.

Switching bike lights on/off

Check that your bike lights are working correctly before every use.

To **switch on** the bike lights, press the (9) button for more than 1 s.

You can use the (11) and (10) buttons to control the brightness of the LEDs on the operating unit.

Switching the push assistance on/off

The walk assistance makes it easier to push your eBike. The speed in this function depends on the selected gear and can reach a maximum of **4 km/h**.

► **The push assistance function must only be used when pushing the eBike.** There is a risk of injury if the wheels of the eBike are not in contact with the ground while using the push assistance.

To **start** walk assistance, press the (8) button for more than 1 s and keep it pressed. The battery charge indicator (3) goes out and a white moving light in the direction of travel shows that it is ready.

To **activate** walk assistance, one of the following actions must occur within the next 10 s:

- Push the eBike forwards.
- Push the eBike backwards.
- Perform a sideways tilting movement with the eBike.

After activation, the motor begins to push and the continuously filling white bars change colour to ice-blue.

If you release the (8) button, walk assistance is stopped. You can reactivate walk assistance within 10 s by pressing the (8) button.

If you do not reactivate walk assistance within 10 s, walk assistance automatically switches off.

Walk assistance is always ended if:

- the rear wheel jams,
- the bicycle cannot move over ridges,
- a body part is blocking the bike crank,
- an obstacle continues to turn the crank,
- you start pedalling,
- the (9) button or on/off button (1) is pressed.

Walk assistance has a roll-away lock, i.e. even after walk assistance has been used, rolling backwards is actively curbed by the drive system for a few seconds, and you cannot push the eBike backwards or can only do so with difficulty.

The push assistance function is subject to local regulations; the way it works may therefore differ from the description above, or the function may even be deactivated completely.

ABS – anti-lock braking system (optional)

If the bicycle is equipped with a Bosch eBike ABS, the ABS LED (4) lights up when the eBike system starts.

After moving off, the ABS internally checks its functionality and the ABS LED goes off.

In the event of a fault, the ABS LED (4) lights up, together with the orange flashing assistance level LED (5). You can acknowledge the error with the select button (2); the flashing assistance level LED (5) goes out. While the ABS LED (4) is lit up, the ABS is not in operation.

For details on the ABS and how it works, please refer to the ABS operating instructions.

Establishing a smartphone connection

In order to be able to use the following eBike functions, a smartphone with the **eBike Flow** app is required.

Connection to the app occurs via a *Bluetooth*® connection.

Switch on the eBike system and do not start riding the eBike. Begin *Bluetooth*® pairing by pressing and holding (> 3 s) the on/off button (1). Release the on/off button (1) as soon as the topmost bar on the battery charge indicator shows the pairing process by flashing blue.

Confirm the connection request in the app.

Activity tracking

In order to record activities, it is necessary to register and log into the **eBike Flow** app.

To record activities, you must consent to the storage of your location data in the app. Without this, your activities cannot be recorded in the app. For location data to be recorded, you must be logged in as the user.

<eBike Lock>

The **<eBike Lock>** can be activated for each user via the **eBike Flow** app. In the process, a key for unlocking the eBike is saved on the smartphone.

The **<eBike Lock>** is automatically enabled in the following cases:

- Switching off the eBike system via the control unit
- Automatically switching off the eBike system

- Removing the on-board computer

If the eBike system is switched on and the smartphone is connected to the eBike via *Bluetooth*®, the eBike will be unlocked.

<eBike Lock> is linked to your **user account**.

If you lose your smartphone, you can log in to your user account on the **eBike Flow** app using another smartphone and unlock then the eBike.

Warning! If you select a setting in the app that could have negative consequences in combination with the **<eBike Lock>** (e.g. deleting your eBike or user account), you will be shown warning messages beforehand. **Please read through these thoroughly and adhere to the warnings that are issued (e.g. before deleting your eBike or user account).**

Setting Up the <eBike Lock>

In order to be able to set up the **<eBike Lock>**, the following conditions must be fulfilled:

- The **eBike Flow** app is installed.
- A user account has been created.
- The eBike is not currently updating.
- The eBike is connected to the smartphone via *Bluetooth*®.
- The eBike is stationary.
- The smartphone is connected to the Internet.
- The eBike battery is sufficiently charged and the charging cable is not connected.

You can set up the **<eBike Lock>** in the **eBike Flow** app in the **Settings** menu item.

From now on, you can deactivate the assistance from your drive unit by switching on **<eBike Lock>** in the **eBike Flow** app. This deactivation can only be can only be overridden if your smartphone is in the vicinity of the eBike system when the system is switched on. To do this, your smartphone must have *Bluetooth*® switched on and the **eBike Flow** app must be active in the background. The **eBike Flow** app does not need to be open. When the **<eBike Lock>** is activated, you can continue to use your eBike without assistance from the drive unit.

Compatibility

The **<eBike Lock>** is compatible with these Bosch eBike product lines:

Drive unit	Product line
BDU374x	Performance Line CX
BDU33xx	Performance Line

How it works

In combination with the **<eBike Lock>**, the smartphone functions similarly to a key for the drive unit. The **<eBike Lock>** is activated by switching off the eBike system. As long as the **<eBike Lock>** is active after the function is switched on, this will be indicated by the operating unit **LED Remote** flashing white and by a padlock symbol on the display.

Note: The **<eBike Lock>** alone does not provide adequate theft protection; it is simply a supplement to a mechanical lock. The **<eBike Lock>** does not provide any form of mechanical lock for the eBike. Only the assistance from the drive unit is deactivated. The drive unit will be unlocked for as long as the smartphone is connected to the eBike via *Bluetooth*®.



If you wish to give other users temporary or permanent access to your eBike or you want to take your eBike to servicing, you will need to deactivate the **<eBike Lock>** in the **eBike Flow** app in the **Settings** menu item. If you wish to sell your eBike, you will also need to delete the eBike from your user account in the **eBike Flow** app in the **Settings** menu item.

When the eBike system is switched off, the drive unit will emit a "Lock" sound (i.e. an audio signal that is played **once**) to indicate that the assistance from the drive unit is switched off.

Note: The audio signal will only be played if the system is switched on.

When the eBike system is switched on, the drive unit will emit two "Unlock" sounds (i.e. an audio signal that is played **twice**) to indicate that the assistance from the drive unit is enabled again.

The "Lock" sound will help you determine whether or not the **<eBike Lock>** on your eBike is active. The audio signal is activated by default, but it can be deactivated in the **eBike Flow** app in the **Settings** menu item by selecting the lock symbol below your eBike.

Note: If you can no longer set up or switch off the **<eBike Lock>**, please contact your bicycle dealer.

Replacing eBike Components and the <eBike Lock>

Replacing the Smartphone

1. Install the **eBike Flow** app on the new smartphone.
2. Log in with **the same** account that was used to activate the **<eBike Lock>**.
3. The **<eBike Lock>** is displayed as set up in the **eBike Flow** app.

Replacing the drive unit

1. The **<eBike Lock>** is displayed as deactivated in the **eBike Flow** app.
2. Activate the **<eBike Lock>** by pushing the **<eBike Lock>** controller to the right.
3. If you are handing in your eBike to a bicycle dealer for maintenance, it is recommended that you temporarily deactivate the **<eBike Lock>** to prevent false alarms.

Software updates

Software updates must be manually started in the **eBike Flow** app.

Software updates are transferred to the operating unit in the background of the app as soon as it is connected to the app. During the update process, a green flashing on the battery charge indicator **(3)** shows the progress. The system is then restarted.

You can control the software updates via the **eBike Flow** app.

Error messages

The operating unit shows whether critical errors or less critical errors occur in the eBike system.

The error messages generated by the eBike system can be read via the **eBike Flow** app or by your bicycle retailer.

Via a link in the **eBike Flow** app, information about the error and support for rectifying the error can be displayed.

Less critical errors

Less critical errors are shown by the assistance level LED **(5)** flashing orange. Pressing the select button **(2)** confirms the error and the assistance level LED **(5)** once again continuously shows the colour of the set assistance level.

You can use the following table to rectify the errors yourself if necessary. Otherwise, please contact your bicycle retailer.

Number	Troubleshooting
523005	The indicated error numbers show that there is interference when the sensors detect the magnetic field. See whether you have lost the magnet while riding.
514001	
514002	
514003	If you are using a magnet sensor, check that the sensor and magnet have been properly installed. Make sure too that the cable to the sensor is not damaged.
514006	If you are using a rim magnet, make sure that you do not have any magnetic field interference in the vicinity of the drive unit.

Critical errors

Critical errors are shown by the assistance level LED **(5)** and the battery charge indicator **(3)** flashing red. Follow the instructions in the table below if a critical error occurs.

Number	Instructions
660001	Do not charge the battery and do not continue to use it.
660002	Please contact your Bosch eBike dealer.
890000	<ul style="list-style-type: none"> – Acknowledge the error code. – Restart the system. If the problem persists: <ul style="list-style-type: none"> – Acknowledge the error code. – Perform software update. – Restart the system. If the problem persists: <ul style="list-style-type: none"> – Please contact your Bosch eBike dealer.

Maintenance and servicing

Maintenance and cleaning

The operating unit must not be cleaned with pressurised water.

Keep the operating unit clean. Dirt can cause faulty brightness detection.

Clean your operating unit using a soft cloth dampened only with water. Do not use cleaning products of any kind.

► **Have all repairs performed only by an authorised bike dealer.**

After-sales service and advice on using products

If you have any questions about the eBike system and its components, contact an authorised bicycle dealer.

For contact details of authorised bike dealerships, please visit www.bosch-ebike.com.

Disposal



The drive unit, on-board computer incl. operating unit, battery, speed sensor, accessories and packaging should be disposed of in an environmentally correct manner.

Check that your personal data has been deleted from the device.

Do not dispose of eBikes and their components with household waste.



In accordance with Directive 2012/19/EU and Directive 2006/66/EC respectively, electronic devices that are no longer usable and defective/drained batteries must be collected separately and recycled in an environmentally friendly manner.

Please return Bosch eBike components that are no longer usable free of charge to an authorised bicycle dealer or to a recycling facility.

Subject to change without notice.



8 Battery



PowerTube 500 | 625 | 750
PowerPack 545 | 725

BBP3750 | BBP3751 | BBP3760 | BBP3761 |
BBP3770 | BBP3771 | BBP3551 | BBP3570

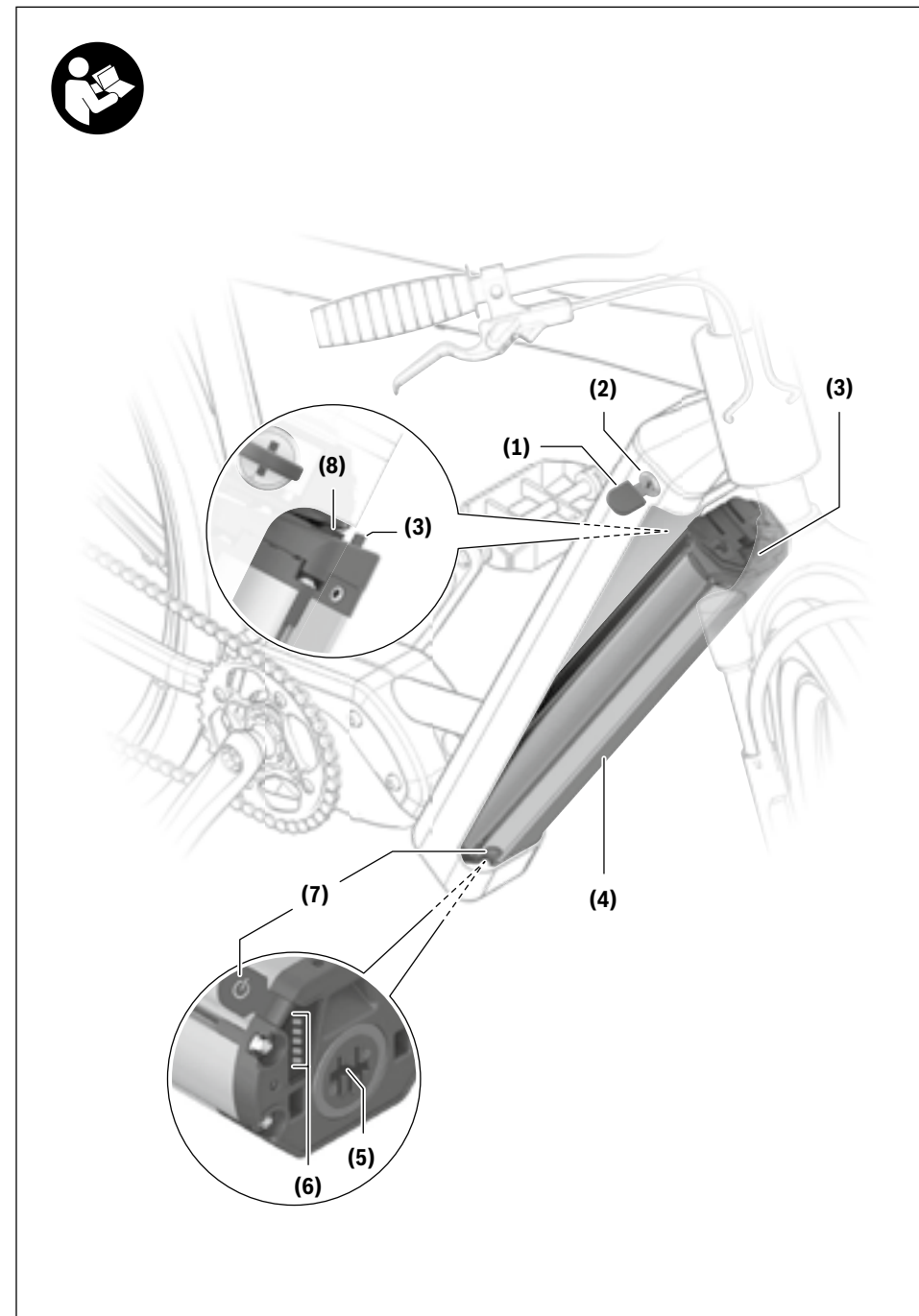

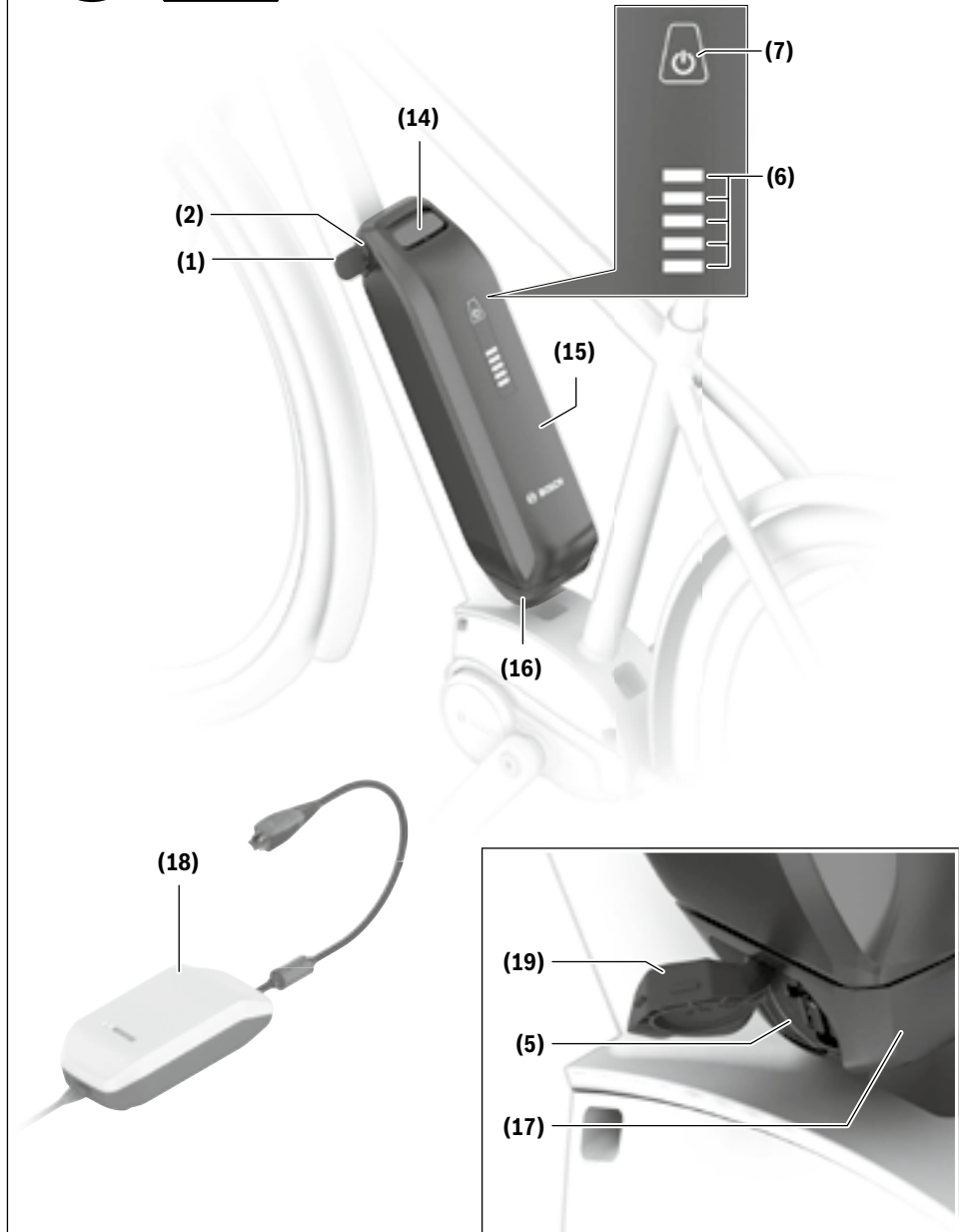
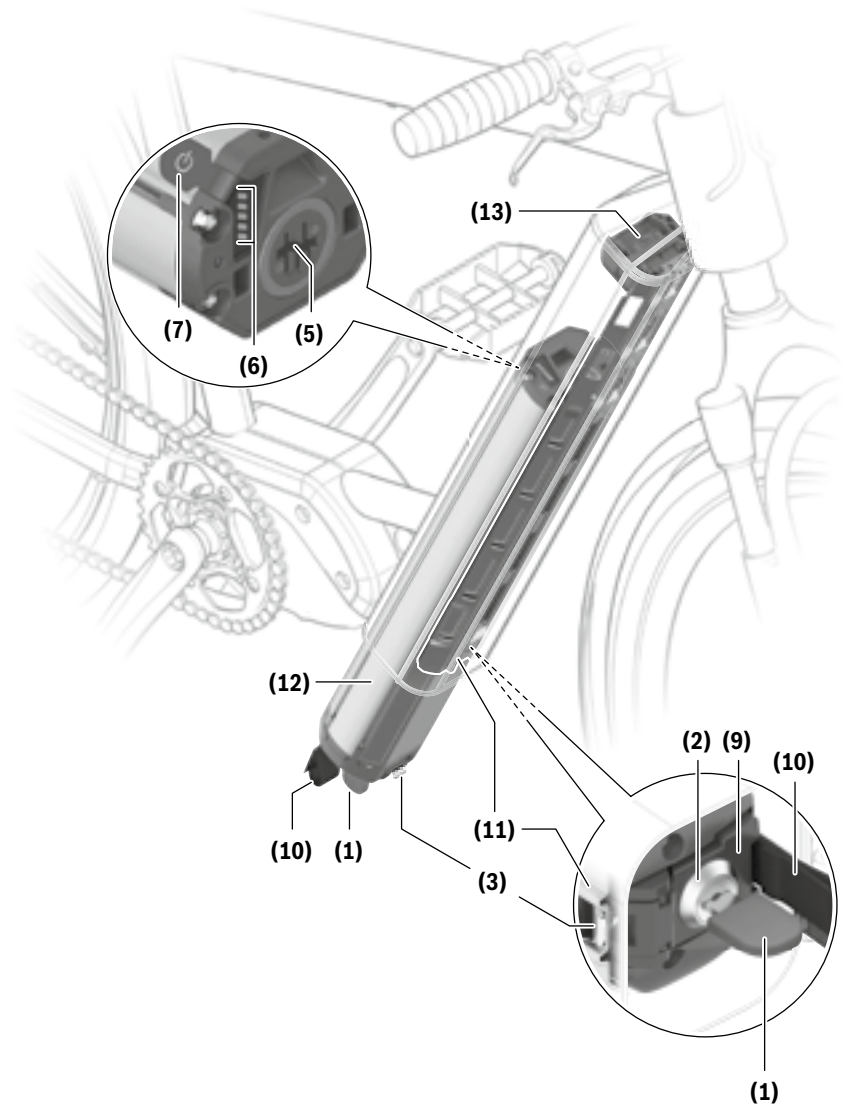

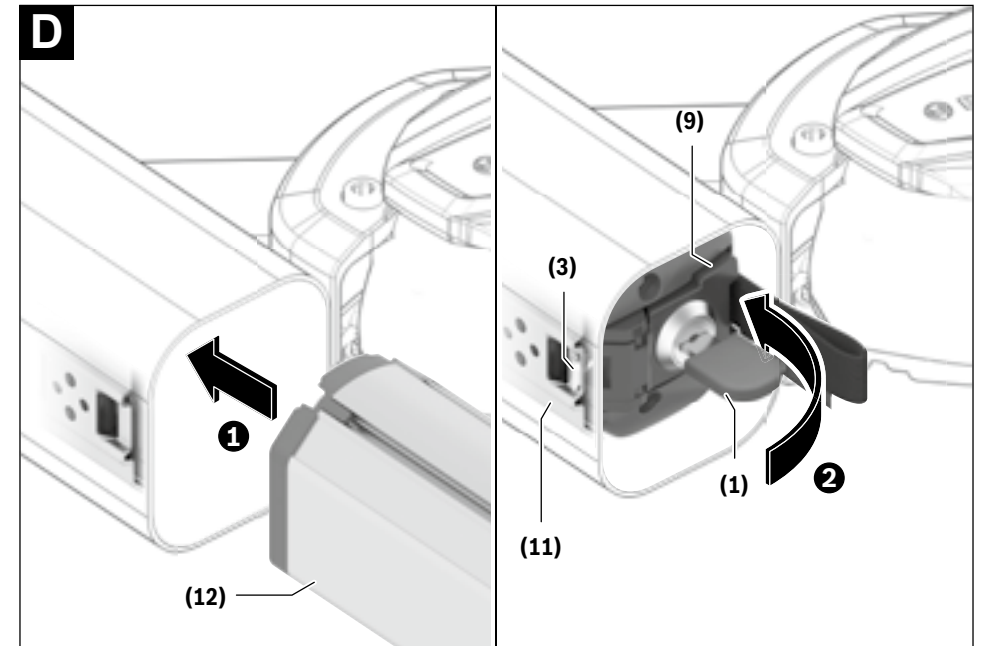
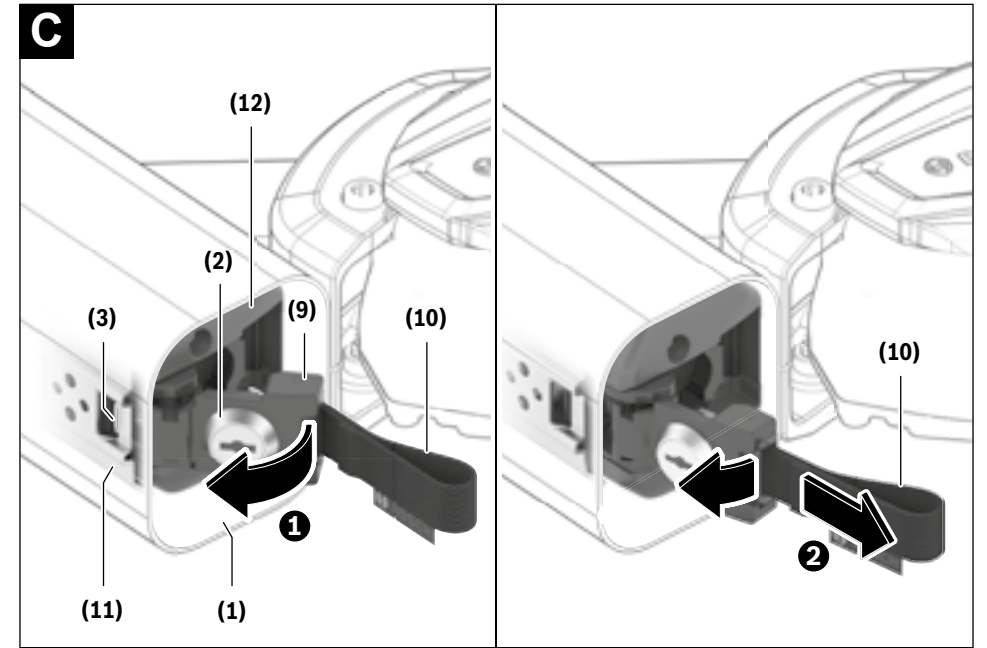
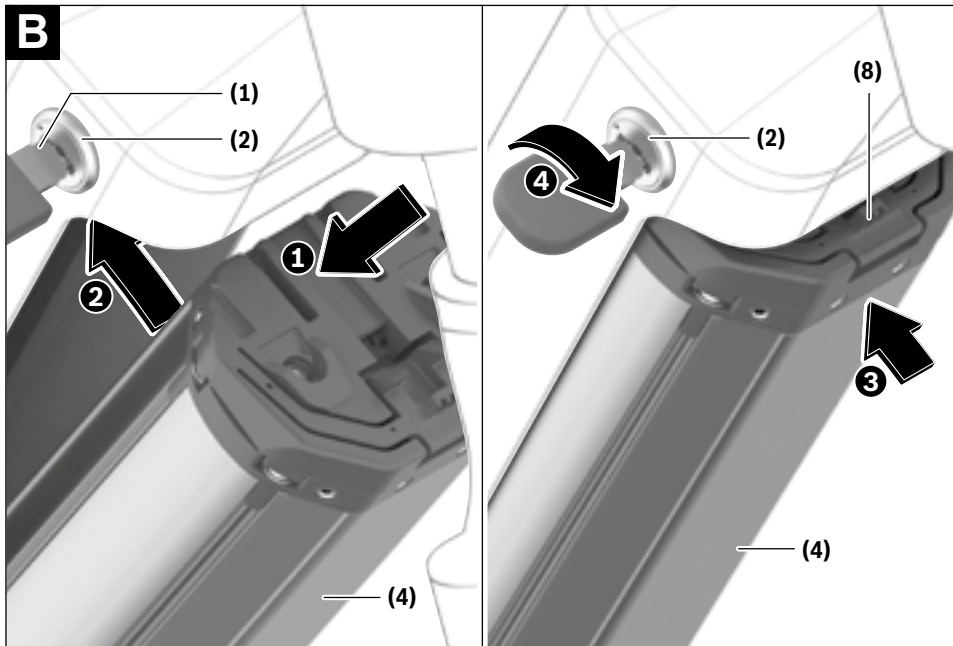
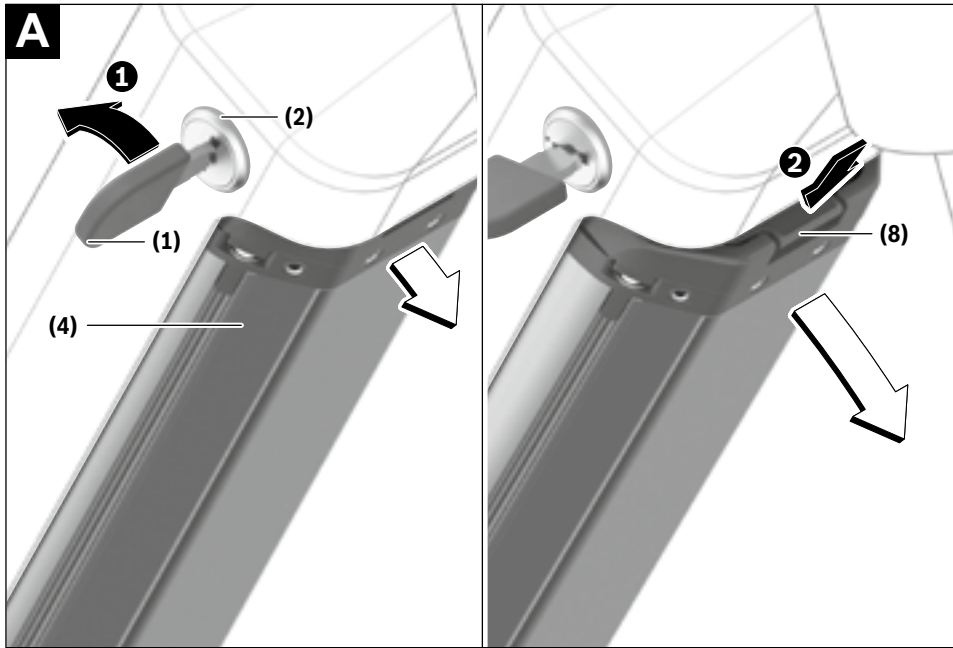

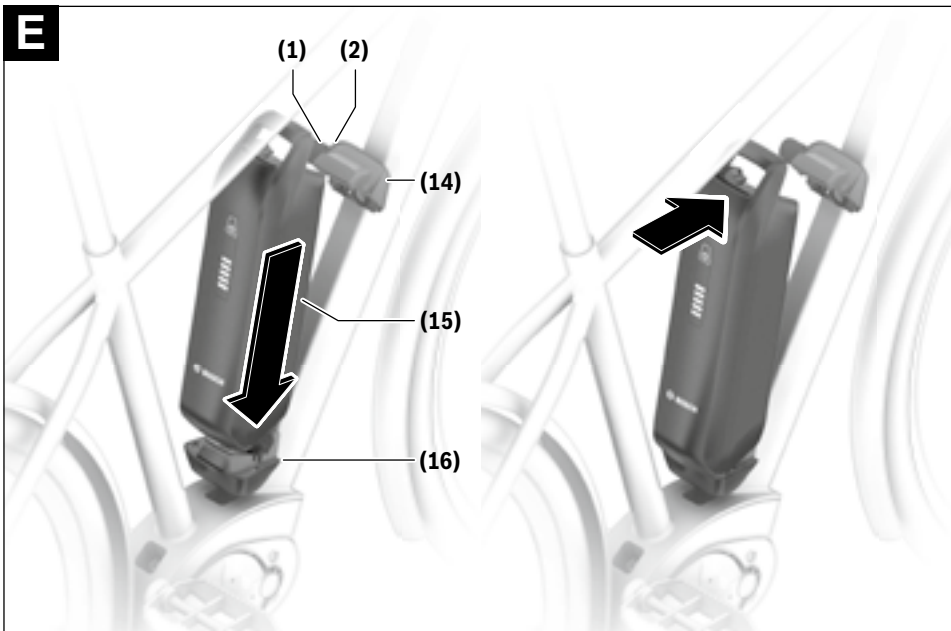

Safety instructions



Read all the safety and general instructions.

Failure to observe the safety and general instructions may result in electric shock, fire and/or serious injury.

The contents of lithium-ion battery cells are flammable under certain conditions. You must therefore ensure that you have read and understood the rules of conduct set out in these operating instructions.

Save all safety warnings and instructions for future reference.

The term **battery** is used in these instructions to mean all original Bosch eBike rechargeable battery packs.

- ▶ **Read and observe the safety warnings and directions contained in all the eBike system operating instructions and in the operating instructions of your eBike.**
- ▶ **Remove the battery from the eBike before beginning work (e.g. inspection, repair, assembly, maintenance, work on the chain, etc.) on the eBike, transporting it with a car or aeroplane, or storing it.** Unintentional activation of the eBike system poses a risk of injury.
- ▶ **Do not open the battery.** There is a risk of short-circuiting. Opening the battery voids any and all warranty claims.
- ▶ **Protect the battery against heat (e.g. prolonged sun exposure), fire and from being submerged in water. Do not store or operate the battery near hot or flammable objects.** There is a risk of explosion.
- ▶ **When the battery is not in use, keep it away from paper clips, coins, keys, nails, screws or other small metal objects that could make a connection from one terminal to another.** A short circuit between the battery terminals may cause burns or a fire. Short circuit damage which occurs in this instance voids any and all warranty claims against Bosch.
- ▶ **Avoid mechanical loads and exposure to high temperatures.** These can damage the battery cells and cause the flammable contents to leak out.
- ▶ **Do not place the charger or the battery near flammable materials. Ensure the battery is completely dry and placed on a fireproof surface before charging.** There is a risk of fire due to the heat generated during charging.
- ▶ **The eBike battery must not be left unattended while charging.**
- ▶ **If used incorrectly, liquid may leak from the battery. Contact with this liquid should be avoided. If contact occurs, rinse off with water. If the liquid comes into contact with your eyes, seek additional medical attention.** Liquid leaking from the battery may cause irritation or scalding.
- ▶ **Batteries must not be subjected to mechanical shock.** There is a risk of the battery being damaged.
- ▶ **The battery may give off fumes if it becomes damaged or is used incorrectly. Ensure the area is well ventil-**

ated and seek medical attention should you experience any adverse effects. The fumes may irritate the respiratory system.

- ▶ **Only charge the battery using original Bosch chargers.** When using chargers that are not made by Bosch, the risk of fire cannot be excluded.
- ▶ **Use the battery only in conjunction with eBikes that have original Bosch eBike drive systems.** This is the only way in which you can protect the battery against dangerous overload.
- ▶ **Use only original Bosch batteries that the manufacturer has approved for your eBike.** Using other batteries can lead to injuries and pose a fire hazard. Bosch accepts no liability or warranty claims if other batteries are used.
- ▶ **Keep the battery away from children.**

The safety of both our customers and our products is important to us. Our eBike batteries are lithium-ion batteries which have been developed and manufactured in accordance with the latest technology. We comply with or exceed the requirements of all relevant safety standards. When charged, these lithium-ion batteries contain a high level of energy. If a fault occurs (which may not be detectable from the outside), in very rare cases and under unfavourable conditions, lithium-ion batteries can catch fire.

Privacy notice

When you connect the eBike to the **Bosch DiagnosticTool 3**, data about the eBike batteries (e.g. temperature, cell voltage, etc.) is transferred to Bosch eBike Systems (Robert Bosch GmbH) for the purposes of product improvement. You can find more information about this on the Bosch eBike website at www.bosch-ebike.com.

Product description and specifications

Intended Use

The Bosch eBike rechargeable batteries are intended exclusively for the power supply of your Bosch eBike drive unit and must not be used for any other purpose.

Product features

The numbering of the components shown refers to the illustrations on the graphics pages at the beginning of the manual.

All representations of bicycle parts, apart from the batteries and their holders, are schematic and may differ from those on your own eBike.

In addition to the functions shown here, changes to software relating to troubleshooting and functional modifications may be introduced at any time.

- (1) Key for the battery lock
- (2) Battery lock
- (3) PowerTube battery safety hook



- (4) PowerTube battery (pivot)
- (5) Socket for charging connector
- (6) Operation/battery charge indicator
- (7) On/off button
- (8) PowerTube battery safety restraint
- (9) Locking mechanism
- (10) Pull strap
- (11) Axial rail
- (12) PowerTube battery (axial)

- (13) Upper axial PowerTube holder
- (14) Upper holder for PowerPack battery
- (15) PowerPack battery
- (16) Lower holder for PowerPack battery (socket without charging option)
- (17) Lower holder for PowerPack battery (socket with charging option)
- (18) Charger
- (19) Charging socket cover

Technical data

Li-ion battery		PowerTube 500	PowerTube 625	PowerTube 750
Product code	Horizontal	BBP3750	BBP3760	BBP3770
Product code	Vertical	BBP3751	BBP3761	BBP3771
Rated voltage	V=	36	36	36
Nominal capacity	Ah	13.4	16.7	20.1
Energy	Wh	500	625	750
Operating temperature	°C	-5 to +40	-5 to +40	-5 to +40
Storage temperature	°C	+10 to +40	+10 to +40	+10 to +40
Permitted charging temperature range	°C	0 to +40	0 to +40	0 to +40
Weight, approx.	kg	3.0	3.6	4.3
Protection rating		IP54	IP54	IP54

Li-ion battery		PowerPack 545	PowerPack 725
Product code		BBP3551	BBP3570
Rated voltage	V=	36	36
Nominal capacity	Ah	14.4	19.2
Energy	Wh	545	725
Operating temperature	°C	-5 to +40	-5 to +40
Storage temperature	°C	+10 to +40	+10 to +40
Permitted charging temperature range	°C	0 to +40	0 to +40
Weight, approx.	kg	3.0	4.0
Protection rating		IP54	IP54

UK
CA

Fitting

- **Ensure the battery is placed on clean surfaces only.**
Avoid getting dirt, e.g. sand or soil, in the charging socket and contacts in particular.

Testing the battery before using it for the first time

Test the battery before charging it for the first time or using it in your eBike.

To do this, press the on/off button (7) to switch the battery on. If none of the LEDs on the battery charge indicator (6) light up, the battery may be damaged.

If at least one (but not all) of the LEDs on the battery charge indicator (6) lights up, the battery will need to be fully charged before using it for the first time.

- **Do not charge or use batteries if they are damaged.**
Contact an authorised bicycle dealer.

Charging the battery

- **A Bosch eBike battery must only be charged using an original Bosch eBike charger.**

Note: The battery is supplied partially charged. To ensure full battery capacity, fully charge the battery in the charger before using it for the first time.

To charge the battery, read and follow the instructions in the operating manual for the charger.

The battery can be charged at any state of charge. Interrupting the charging process does not damage the battery.

The battery has a temperature monitoring function which only allows it to be charged within a temperature range of 0 °C to 40 °C.



If the temperature of the battery is outside this charging range, three of the LEDs on the battery charge indicator (6) will flash. Disconnect the battery from the charger and let it acclimatise.

Do not reconnect the battery to the charger until it has reached the correct charging temperature.

Battery charge indicator

The five LEDs on the battery charge indicator (6) indicate the battery's state of charge when the battery is switched on.

Each LED represents approximately 20% of the charging capacity. When the battery is fully charged, all five LEDs will be lit.

The battery's state of charge when switched on is also shown on the display of the on-board computer. Read and follow the instructions in the operating manuals for the drive unit and on-board computer.

If the battery capacity is less than 10%, the last remaining LED will flash.

If the battery capacity is less than 5%, all the LEDs on the battery charge indicator (6) on the battery will go out. The display function of the on-board computer, however, will carry on working.

Once charging is complete, disconnect the battery from the charger and the charger from the mains.

Inserting and removing the battery

- **Always switch off the battery and the eBike system when inserting the battery into the holder or removing it from the holder.**

Removing the PowerTube battery (pivot) (see figure A)

- ❶ To remove the PowerTube battery (4), open the lock (2) using the key (1). The battery will be unlocked and fall into the safety restraint (8).
- ❷ Press on the safety restraint from above. The battery will be unlocked completely and fall into your hand. Pull the battery out of the frame.

Note: As a result of varying designs, the battery may need to be inserted and removed using a different method. Read the operating instructions of the eBike manufacturer.

Inserting the PowerTube battery (pivot) (see figure B)

In order for the battery to be inserted, the key (1) must be inserted into the lock (2) and the lock must be open.

- ❶ To insert the PowerTube battery (4), place it so that its contacts are in the lower holder of the frame.
- ❷ Push the battery upwards until it is held by the safety restraint (8).
- ❸ Hold the lock open with the key and press the battery upwards until you hear it click into place. Check that the battery is secure in all directions.
- ❹ Always secure the battery by closing the lock (2) – otherwise the lock may open and the battery may fall out of the holder.

Always remove the key (1) from the lock (2) after locking it. This prevents both the key from falling out and the battery from being removed by unauthorised third parties when the eBike is not in use.

Removing the PowerTube battery (axial) (see figure C)

- ❶ To remove the PowerTube battery (12), open the lock (2) using the key (1), remove the key (1) and fold the locking mechanism (9) to the side.
- ❷ Use the pull strap (10) to pull the battery (12) out of the frame and keep hold of it so that it does not fall out of the frame.

Note: As a result of varying designs, the battery may need to be inserted and removed using a different method. Read the operating instructions of the eBike manufacturer.

Inserting the PowerTube battery (axial) (see figure D)

In order for the battery to be inserted, the locking mechanism (9) must be folded to the side. At this point, the key (1) must not be inserted in the battery lock (2).

- ❶ To insert the PowerTube battery, insert it into the frame with the socket for the charging connector (5) facing upwards until the battery clicks into place. Ensure that the battery is aligned correctly.
- ❷ Close the locking mechanism (9), insert the key (1) into the battery lock (2) and secure the battery. Make sure that the safety hook (3) is hooked in at the opening of the axial rail (11).
- ❸ Check that the battery is secure in all directions.

Always remove the key (1) from the lock (2) after locking it. This prevents both the key from falling out and the battery from being removed by unauthorised third parties when the eBike is not in use.

Inserting and Removing the PowerPack battery (see figure E)

In order to insert the battery, the key (1) must not be inserted in the lock (2).

To insert the PowerPack battery (15), place it so that its contacts are in the lower holder (16) on the eBike. Tilt it into the upper holder (14) as far as possible until you hear it click into place.

Check that the battery is secure in all directions.

Do not ride with the key (1) inserted. Make sure that the key is no longer inserted when you park the eBike.

To remove the PowerPack battery (15), switch it off and open the lock (2) using the key (1).



Tilt the battery out of the upper holder (14) and pull it out of the lower holder (16).

Operation

Start-up

► **Use only original Bosch batteries that the manufacturer has approved for your eBike.** Using other batteries can lead to injuries and pose a fire hazard. Bosch accepts no liability or warranty claims if other batteries are used.

Switching on/off

Switching on the battery is one way to switch on the eBike system. Read and follow the instructions in the operating manuals for the drive unit and on-board computer.

Before switching on the battery, i.e. the eBike system, make sure that the lock (2) is closed.

To **switch on** the battery, press the on/off button (7). Do not use any sharp or pointed objects to press the button. The LEDs on the indicator (6) will light up, indicating the battery's state of charge at the same time.

Note: If the battery capacity is less than 5 %, none of the LEDs on the battery charge indicator (6) will light up. Whether the eBike system is switched on is only visible on the on-board computer/control unit.

To **switch off** the battery, press the on/off button (7) again. The LEDs on the indicator (6) will go out. This will also switch the eBike system off.

If no power is drawn from the eBike drive for about 10 minutes (e.g. because the eBike is not moving) and no button is pressed on the on-board computer or the control unit of the eBike, the eBike system will switch off automatically.

The battery is protected against deep discharge, overloading, overheating and short-circuiting by the "Battery Management System (BMS)". In the event of danger, a protective circuit switches the battery off automatically.



If a fault is detected in the battery, two of the LEDs on the battery charge indicator (6) will flash. Contact an authorised bicycle dealer if this happens.

Recommendations for optimal handling of the battery

The service life of the battery can be extended if it is looked after well and especially if it is stored at the correct temperature.

As it ages, however, the capacity of the battery will diminish, even with good care.

A significantly reduced operating time after charging indicates that the battery has deteriorated. The battery should be replaced.

Recharging the battery before and during storage

When you are not going to use the battery for an extended period (longer than three months), store it at a state of charge of around 30 % to 60 % (when two to three of the LEDs on the battery charge indicator (6) are lit).

Check the state of charge after six months. If only one of the LEDs on the battery charge indicator (6) is lit, charge the battery back up to around 30 % to 60 %.

Note: If the battery is stored with no charge for an extended period of time, it may become damaged despite the low self-discharge and the battery capacity could be significantly reduced.

Leaving the battery permanently connected to the charger is not recommended.

Storage conditions

If possible, store the battery in a dry, well-ventilated place. Protect it against moisture and water. When the weather conditions are bad, it is advisable to remove the battery from the eBike and store it in a closed room until you use it next, for example.

Store the eBike batteries in the following locations:

- In a room with a smoke alarm
- Away from combustible or easily flammable objects
- Away from heat sources

To ensure an optimum service life, store the eBike batteries at temperatures between 10 °C and 20 °C. Never store them at temperatures below -10 °C or above 60 °C.

Make sure that the maximum storage temperature is not exceeded. Do not leave the battery in your car in the summer, for example, and store it away from direct sunlight.

Leaving the battery on the bicycle for storage is not recommended.

Action in the event of a fault

The Bosch eBike rechargeable battery must not be opened, including for repairs. There is a risk of the Bosch eBike rechargeable battery catching fire, e.g. as a result of a short circuit. This risk continues to apply on any Bosch eBike rechargeable battery **ever** opened, even at a later point in time.

In the event of a fault, do not have your Bosch eBike rechargeable battery repaired; instead, have it replaced with an original Bosch eBike rechargeable battery by your specialist retailer.

Maintenance and servicing

Maintenance and cleaning

► **The battery must not be submerged in water or cleaned using a jet of water.**

Keep the battery clean and avoid contact with skincare products and insect repellent. Clean it carefully with a soft, damp cloth.

Clean and lightly grease the connector pins occasionally.

Please contact an authorised bicycle dealer if the battery is no longer working.

After-sales service and advice on using products

If you have any questions about the batteries, contact an authorised bicycle dealer.

► **Note down the key manufacturer and number on the key (1).** Contact an authorised bicycle dealer if you lose the key. Give them the name of the key manufacturer and the number on the key.

For contact details of authorised bicycle dealers, please visit www.bosch-ebike.com.

Transport

► **If you transport your eBike attached to the outside of your car, e.g. on a bike rack, remove the on-board computer and the eBike battery to avoid damaging them.**

The batteries are subject to legislation on the transport of dangerous goods. Private users can transport undamaged batteries by road without having to comply with additional requirements.

When batteries are transported by commercial users or third parties (e.g. air transport or forwarding agency), special requirements on packaging and labelling (e.g. ADR regulations) must be met. When preparing items for shipping, a dangerous goods expert can be consulted as required.

Do not ship batteries if the housing is damaged or the rechargeable battery is not fully functional. Use only the original Bosch packaging for transport. Apply tape over exposed contacts and pack the battery such that it cannot move around inside the packaging. Inform your parcel service that the package contains dangerous goods. Please also observe any additional national regulations should these exist.

If you have any questions about transporting the batteries, contact an authorised bicycle dealer. You can also order suitable transport packaging from the dealer.

Disposal



Batteries, accessories and packaging should be recycled in an environmentally friendly manner.

Do not dispose of batteries along with household waste.

Apply tape over the contact surfaces of the battery terminals before disposing of batteries.

Do not touch severely damaged eBike batteries with your bare hands – electrolyte may escape and cause skin irritation. Store the defective battery in a safe location outdoors. Cover the terminals if necessary and inform your dealer. They will help you to dispose of it properly.



In accordance with Directive 2012/19/EU and Directive 2006/66/EC respectively, electronic devices that are no longer usable and defective/drained batteries must be collected separately and recycled in an environmentally friendly manner.



Li-ion:

Please observe the information in the section on (see "Transport", page English – 5).

Please return batteries that are no longer usable to an authorised bicycle dealer.

Subject to change without notice.



9 Charger



BPC3400

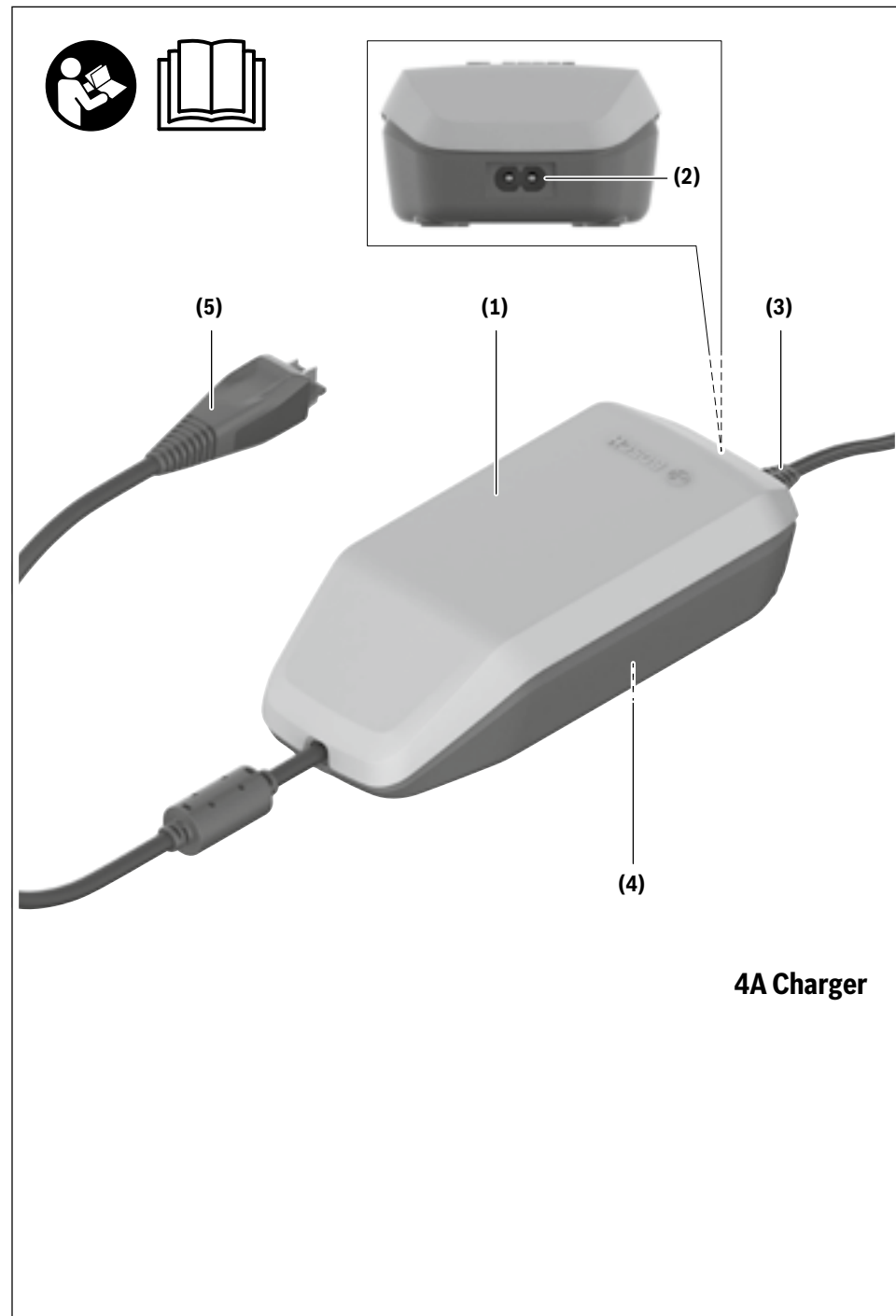
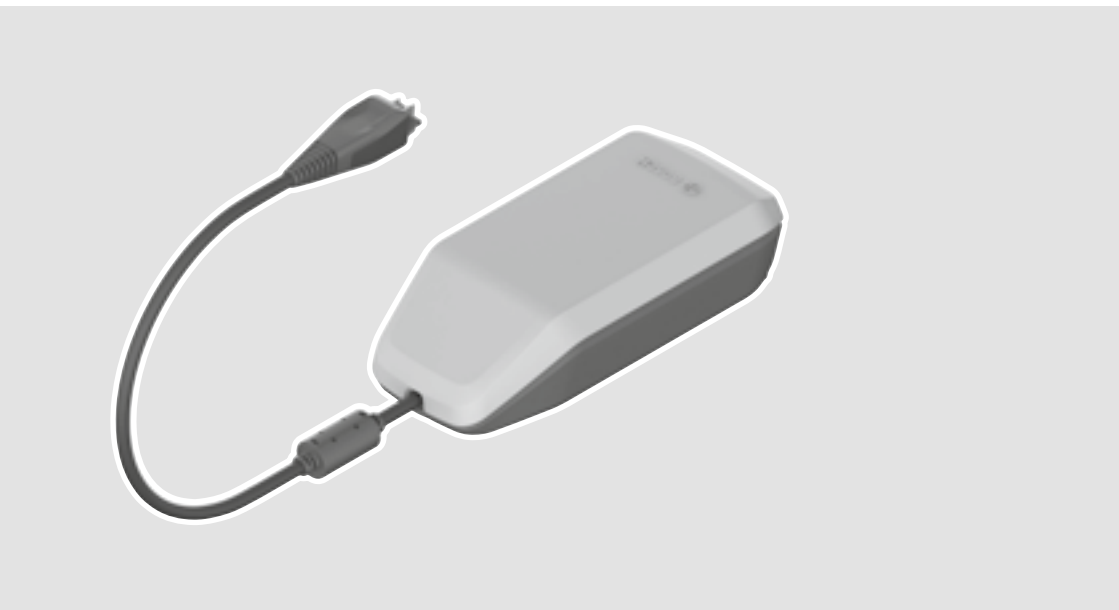

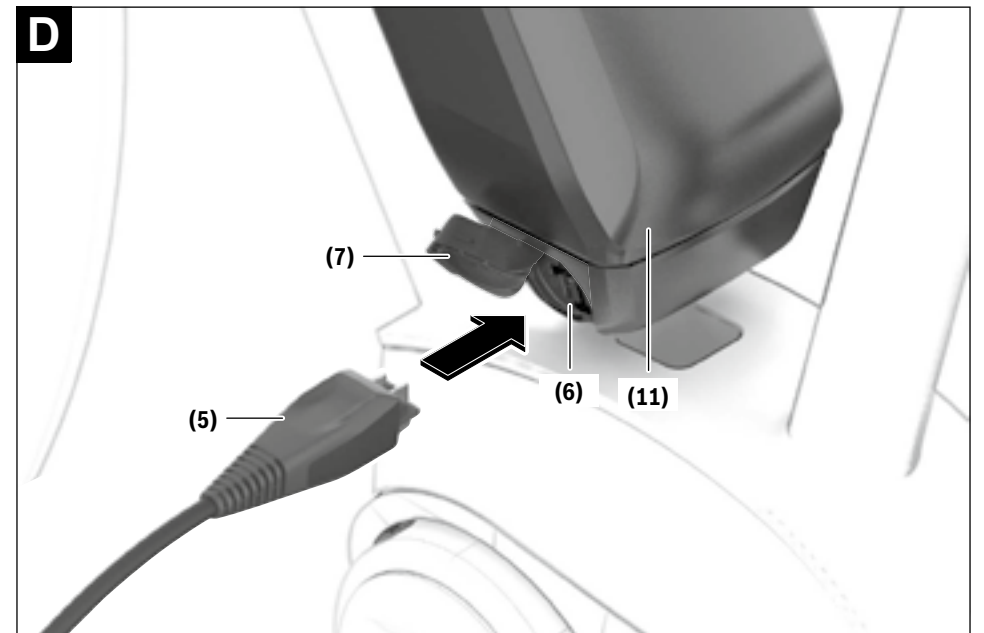
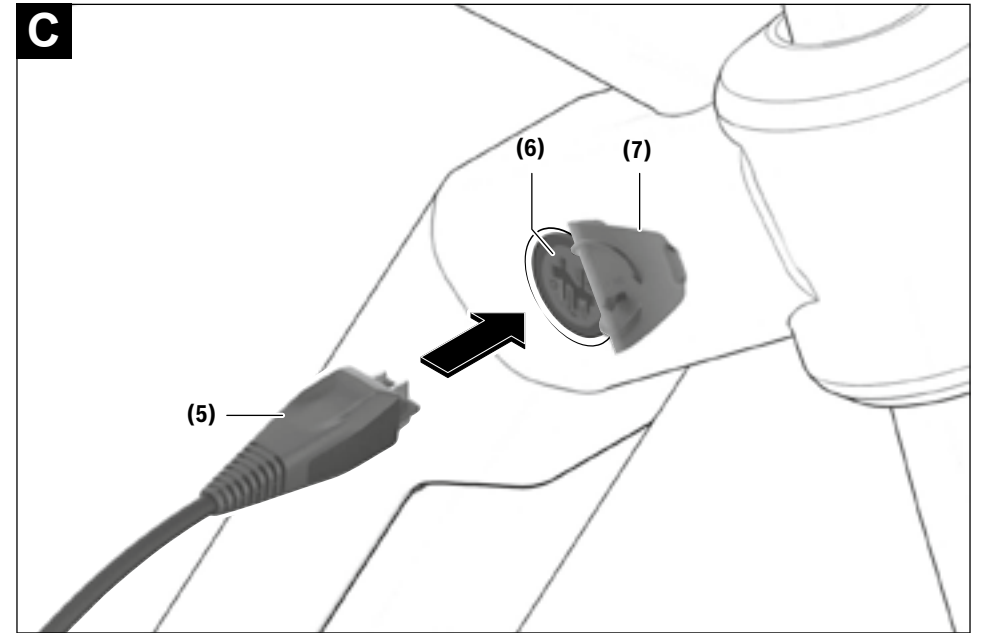
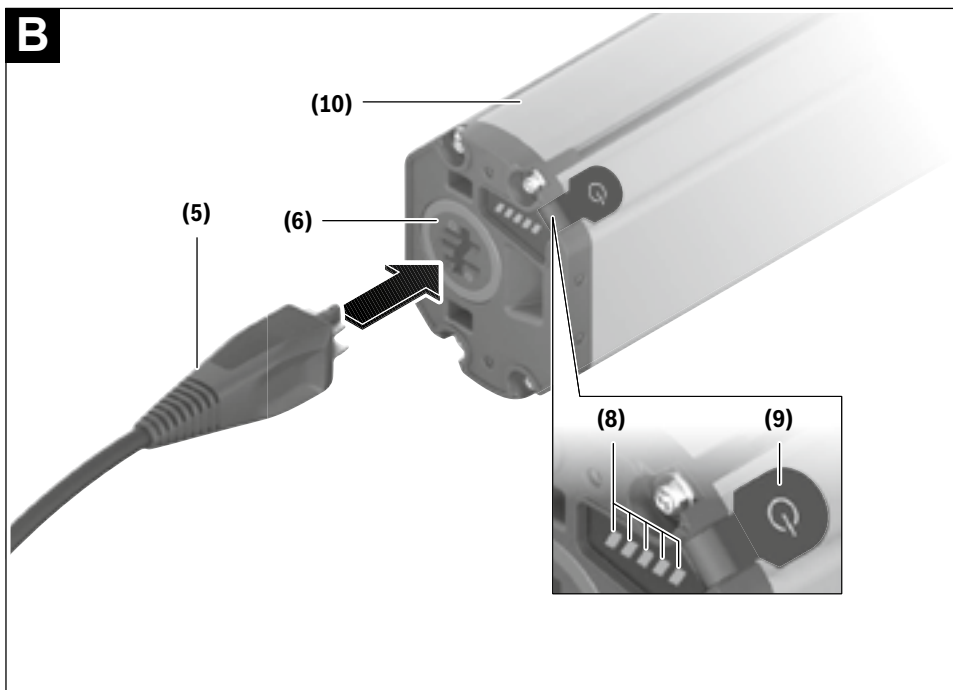
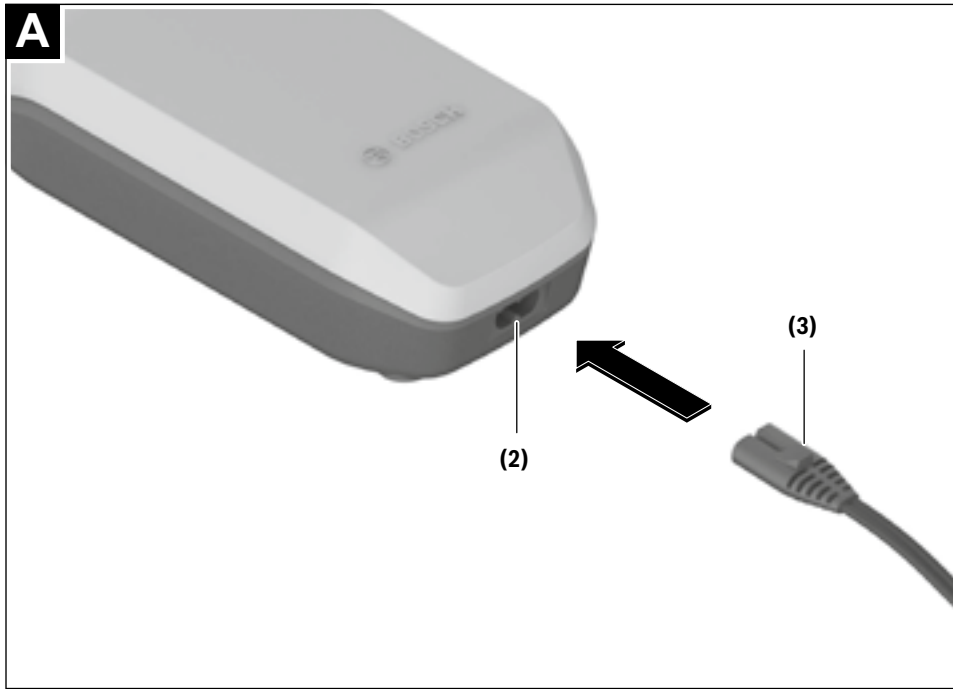

Safety instructions



Read all the safety and general instructions. Failure to observe the safety and general instructions may result in electric shock, fire and/or serious injury.

Save all safety warnings and instructions for future reference.

The term **battery** is used in these instructions to mean all original Bosch eBike rechargeable battery packs.

- ▶ **Read and observe the safety warnings and directions contained in all the eBike system operating instructions and in the operating instructions of your eBike.**
- ▶ **Carefully cover the charging socket with the flap after charging the eBike.** This ensures that no dirt or water gets in.



Do not expose the charger to rain or wet conditions. If water enters a charger, there is a risk of electric shock.

- ▶ **Charge only Bosch lithium-ion batteries that are approved for use in eBikes. The battery voltage must match the battery charging voltage of the charger.** Otherwise there is a danger of fire and explosion.
- ▶ **Keep the charger clean.** Dirt poses a risk of electric shock.

- ▶ **Always check the charger, cable and plug before use. Stop using the charger if you discover any damage. Do not open the charger.** Damaged chargers, cables and plugs increase the risk of electric shock.
- ▶ **Do not operate the charger on an easily ignited surface (e.g. paper, textiles, etc.) or in a flammable environment.** There is a risk of fire due to the charger heating up during operation.
- ▶ **Take care if you touch the charger while it is charging. Wear protective gloves.** The charger can get very hot, especially when the ambient temperature is high.
- ▶ **The battery may give off fumes if it becomes damaged or is used incorrectly. Ensure the area is well ventilated and seek medical attention should you experience any adverse effects.** The fumes may irritate the respiratory system.
- ▶ **The eBike battery must not be left unattended while charging.**
- ▶ **Children or persons who, owing to their physical, sensory or mental limitations or to their lack of experience or knowledge, are not capable of safely operating the charger may only use this charger under supervision or after having been instructed by a responsible person.** Otherwise, there is a danger of operating errors and injuries.
- ▶ A sticker in English is adhered to the bottom of the charger (marked **(4)** in the diagram on the graphics page). This says:

Use ONLY with BOSCH lithium-ion rechargeable batteries!

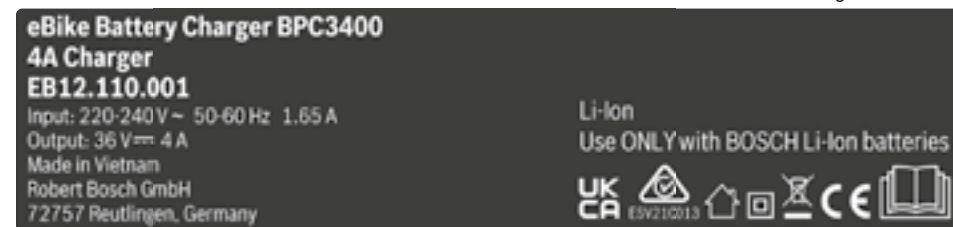

Product description and specifications

Intended Use

In addition to the functions shown here, changes to software relating to troubleshooting and functional modifications may be introduced at any time.

The Bosch eBike chargers are intended exclusively for charging Bosch eBike batteries and must not be used for any other purpose.

The Bosch eBike charger depicted here is compatible with Bosch eBike batteries from the new system generation **the smart system**.

Product features

The numbering of the components shown refers to the illustrations on the graphics pages at the beginning of the manual.

Individual illustrations in these operating instructions may differ slightly from the actual conditions depending on the equipment of your eBike.

- (1) Charger
- (2) Device socket
- (3) Device connector
- (4) Charger safety instructions
- (5) Charging connector
- (6) Socket for charging connector
- (7) Charging socket cover

- (8) Operation/battery charge indicator
- (9) Battery on/off button
- (10) PowerTube
- (11) PowerPack

Technical data

Charger	4A Charger	
Product code	BPC3400	
Rated voltage	V~	220 ... 240
Frequency	Hz	50 ... 60
Battery charging voltage	V=	36
Charging current (max.)	A	4
Charging time for PowerTube 750, approx. ^{A)}	h	6
Charging time for PowerPack 400, approx. ^{A)}	h	3.5
Operating temperature	°C	0 to 40
Storage temperature	°C	10 to 40
Weight, approx.	kg	0.7
Protection rating	IP40	

A) You can find the charging times for additional batteries at: <http://www.bosch-ebike.com>

The specifications apply to a rated voltage [U] of 230 V. These specifications may vary at different voltages and in country-specific models.

UK
CA

Operation

Start-up

Connecting the charger to the mains (see figure A)

- ▶ **Pay attention to the mains voltage.** The voltage of the power source must match the voltage specified on the rating plate of the charger. Chargers marked 230 V can also be operated at 220 V.

Plug the device connector **(3)** of the power cable into the device socket **(2)** on the charger.

Connect the power cable (country-specific) to the mains.

Charging the removed battery (see figure B)

Switch the battery off and remove it from its holder on the eBike. When doing so, read and observe the operating instructions of the battery.

- ▶ **Ensure the battery is placed on clean surfaces only.** Avoid getting dirt, e.g. sand or soil, in the charging socket and contacts in particular.

Plug the charging connector **(5)** of the charger into the socket **(6)** on the battery.

Charging the battery on the bike (see figures C and D)

Switch the battery off. Clean the cover of the charging socket **(7)**. Avoid getting dirt, e.g. sand or soil, in the charging socket and contacts in particular. Lift the cover of the charging socket **(7)** and plug the charging connector **(5)** into the charging socket **(6)**.

- ▶ **There is a risk of fire due to the charger heating up during charging. Ensure the battery on the bike is completely dry and placed on a fireproof surface before charging.** If this is not possible, remove the battery from the holder and charge it in a more suitable location. When doing so, read and observe the operating instructions of the battery.

Charging process

The charging process begins as soon as the charger is connected to the battery or charging socket on the bike and to the mains.

Note: The charging process is only possible when the temperature of the eBike battery is within the permitted charging temperature range.

Note: The drive unit is deactivated during the charging process.

The battery can be charged with and without the on-board computer. When charging without the on-board computer, the charging procedure can be observed on the battery charge indicator.

When the on-board computer is connected, a charging notification appears on the display.

The state of charge is displayed by the battery charge indicator **(8)** on the battery and by the bars on the on-board computer.

The LEDs on the battery charge indicator **(8)** flash during the charging process. Each solid illuminated LED represents approximately 20 % of the charging capacity. The flashing LED indicates the next 20 % currently charging.

Once the eBike battery is fully charged, the LEDs go out immediately and the on-board computer is switched off. The charging process is terminated. The state of charge can be displayed for 5 seconds by pressing the on/off button **(9)** on the eBike battery.

Disconnect the charger from the mains and the battery from the charger.



When the battery is disconnected from the charger, the battery is automatically switched off.

Note: If you have charged the battery on the bike, carefully close the charging socket **(6)** with the cover **(7)** after charging, so that no dirt or water can get in.

If the charger is not disconnected from the battery after charging, after a few hours the charger will switch itself back on, check the state of charge of the battery and begin the charging procedure again if necessary.



Errors – causes and corrective measures

Cause	Corrective measures
 <p>Battery defective</p>	<p>Two LEDs flash on the battery.</p> <p>Contact an authorised bike dealership.</p>
 <p>Battery too warm or too cold</p>	<p>Three LEDs flash on the battery.</p> <p>Disconnect the battery from the charger until the charging temperature range has been reached.</p> <p>Do not reconnect the battery to the charger until it has reached the correct charging temperature.</p>
 <p>The charger is not charging.</p>	<p>No LEDs flashing (one or more LEDs will remain permanently lit depending on the state of charge of the eBike battery).</p> <p>Contact an authorised bike dealership.</p>
Charging not possible (no indicator on battery)	
Connector not attached properly	Check all connections.
Battery contacts dirty	Carefully clean the battery contacts.
Plug socket, cable or charger defective	Check the mains voltage, have the charger checked over by a bike dealership.
Battery defective	Contact an authorised bike dealership.

Maintenance and servicing

Maintenance and cleaning

If the charger fails, please contact an authorised bike dealership.

After-sales service and advice on using products

If you have any questions about the eBike system and its components, contact an authorised bicycle dealer.

For contact details of authorised bike dealerships, please visit www.bosch-ebike.com.

Disposal

Chargers, accessories and packaging should be recycled in an environmentally friendly manner.

Do not dispose of chargers along with household waste.

Check that your personal data has been deleted from the device.

Only for EU countries:



According to the European Directive 2012/19/ EU on Waste Electrical and Electronic Equipment and its implementation into national law, chargers that are no longer usable must be collected separately and disposed of in an environmentally friendly manner.

Please return Bosch eBike components that are no longer usable free of charge to an authorised bicycle dealer or to a recycling facility.

Subject to change without notice.

Royal Dutch Gazelle Bikes

2867 Mission Street
Santa Cruz, CA 95060

Royal Dutch Gazelle N.V.

Wilhelminaweg 8
6951 BP Dieren
The Netherlands

www.gazellebikes.com

BOSCH_US_SMART_E02_23

ROYAL DUTCH
Gazelle

